

wej-it[®]





















FASTENING
SYSTEMS

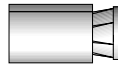
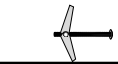
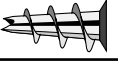

PRODUCT CATALOG

ANCHOR SELECTION GUIDE

BASE MATERIAL

		Concrete	Grout-filled Concrete Block	Hollow Concrete Block	Solid Brick	Hollow Brick	Stone	Approvals	Page No.	
Original wej-it		•						ICC-ES Legacy Report; City of LA	2-3	
Ankr-Tite		•						ICC-ES Legacy Report; City of LA; Dade County	4-6	
Power-Sert		•						Various DOT's	20-21	
Power-Drop		•						ICC-ES Legacy Report	10	
Sleeve Anchor		•	•	•	•	•	■		8-9	
Inject-Tite Epoxy		•	•	•	•	•		ICC-ES Legacy Report; Various DOT's; Dade County	25-29	
AWF		•	•	•	•	•	■		22-24	
Chemical Capsules		•						Various DOT's	32-33	
Hammer Capsules		•						Various DOT's	30-31	
Drop-Ins		•	■				■	UL	11	
Center Pin Drive		•	•				■	ICC-ES Legacy Report	7	
Expansion Shields		•	•		•				14	
Drive Nails		•	•	•	•	•	■		13	
Concrete Screws		•	•	•	•	•	■	ICC-ES Legacy Report	12	
Lead Expansion Anchors		•	•	•	•	•	■		15	
Lag Screw Shields		•	•	•	•	•	■		15	
Machine Screw Anchors		•	•		•		■		16	
Toggle Bolts		Base Material Plywood and Gypsum Drywall		•		•			17	
Drywall Augers										16
Hollow Wall Anchors				•		•				18
Plastic Toggles				•	•	•				17
Plastic Plugs					•	•	•	■		19
Plastic Conical Anchors				•	•	•		■		19

From time-to-time, **wej-it**® products are purchased from reputable alternative sources. Physical characteristics and holding values are similar, but may not be exact. **wej-it**® recommends that specifiers and users of the products exercise good engineering judgement in applying these values. Always use at least a 4:1 safety factor when determining design anchor capacity.

• Suitable ■ May be suitable depending upon application

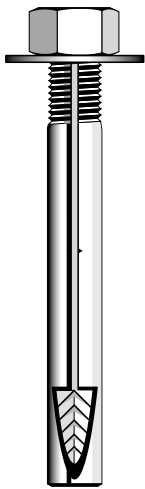

The Original **wej-it**® Wedge Anchors



KEY FEATURES/BENEFITS

- **Time-Tested, Proven Reliability.** An industry standard for over 50 years.
- **Fully Assembled and Ready to Use.** Unparalleled job-site convenience.
- **BOLT SIZE IS HOLE SIZE.®** Allows precision placement of equipment through pre-drilled holes.
- **Exclusive “Positive Wedge Connections.”** Minimizes wedge loosening due to vibratory loads.

SPECIFICATIONS, APPROVALS AND LISTINGS

TYPE	
Zinc Plating	ASTM B-633, Type III, SCI
ICC-ES Legacy Report	#1821
City of Los Angeles	#RR 24939
State DOT Approvals	Please call Customer Service for specific information by state.
Federal Specifications	QQZ-325C, Type II, Class 3 (Clear Chromate added) FFS-325, Group II, Type 4, Class 1

MAXIMUM TENSILE AND SHEAR CAPACITY FOR STATIC LOADS

Anchor & Hole Size	LIMESTONE AGGREGATE			UNREINFORCED STONE AGGREGATE CONCRETE ZINC PLATED CARBON STEEL								UNREINFORCED LIGHTWEIGHT (IDEALITE)		
	Embed-ment (in)	2000 psi Tension (lbs)	2000 psi Shear (lbs)	Embed-ment (in)	3000 psi Tension (lbs)	3000 psi Shear (lbs)	5000 psi Tension (lbs)	5000 psi Shear (lbs)	7000 psi Tension (lbs)	7000 psi Shear (lbs)	Embed-ment (in)	5000 psi Tension (lbs)	5000 psi Shear (lbs)	
1/4	1 1/8	1132	1211	1 1/8	1320	1751	1760	2316	2464	2494	1 1/2	1861	1947	
1/4	1 3/4	1256	1211	1 1/2	1856	1751	2473	2316	3462	2494	•	•	•	
5/16	1 1/4	1308	1210	1 1/4	2057	1839	2742	2530	3939	3439	1 1/2	2493	3064	
5/16	2	1181	1210	1 3/4	2389	1839	3185	2530	4459	3439	•	•	•	
3/8	1 1/4	994	1223	1 1/2	2876	4286	3834	5213	5368	5658	1 3/4	3125	4289	
3/8	4	1728	1223	4	3488	4286	4650	5213	6510	5658	•	•	•	
1/2	1 3/4	1542	3009	2 1/4	3473	7138	5789	10748	8105	11550	2 1/4	4778	9833	
1/2	6	2695	3009	5	4809	7138	8015	10748	11221	11550	•	•	•	
5/8	•	•	•	3 1/2	7582	10719	12636	15583	17690	16700	2 1/2	6455	12500	
5/8	•	•	•	4 3/4	9179	10719	15299	15583	21419	16700	•	•	•	
3/4	•	•	•	3	11579	15537	19299	21000	27019	23103	3 1/2	17293	19050	
3/4	•	•	•	7	15444	15537	25740	21000	36036	23103	•	•	•	
7/8	•	•	•	4 1/2	15266	•	25444	25099	33622	28718	•	•	•	
7/8	•	•	•	7	16992	•	28320	25099	39648	28718	•	•	•	
1	•	•	•	5 1/2	16351	•	27252	33083	38153	35700	4 1/2	21616	31666	
1	•	•	•	7	17837	•	29728	33083	41619	35700	•	•	•	
Source	1			2								2		

Sources (available upon request): 1) University of Texas, Austin, TX (using new ICBO-ES testing criteria); 1993. 2) AA Engineers & Associates, Inc., Denver, CO; 1981.

NOTES:

- Information provided only for the use of a qualified design engineer. Use of technical data by persons not qualified could cause serious damage, injury, or even death.
- Ultimate values shown. For static loads, use one-fourth of the maximum tensile and shear capacities for the recommended 4:1 safety factor.
- Tested to ASTM E-488 Test Standard.
- Sources (available upon request): 1) U.S. Testing Co., Tulsa, OK



ORDER INFORMATION

Catalog Number	Anchor Carbon Steel Zinc Plated	Anchor Diameter & Length (in)	Minimum Embedment (in)	Thread Length (in)	Quantity Box/ Carton
1413		1/4 x 1 3/4	1	1/2	100/600
Z1413					20/400
1423		1/4 x 2 3/4	1	1/2	100/600
Z1423					20/400
1430		1/4 x 3	1	1/2	100/600
Z1430					20/400
5620		5/16 x 2	1 1/4	5/8	100/600
Z5620					20/400
5630		5/16 x 3	1 1/4	5/8	100/600
Z5630					20/400
3820		3/8 x 2	1 1/2	3/4	100/600
Z3820					20/400
3823		3/8 x 2 3/4	1 1/2	3/4	100/600
Z3823					20/400
3832		3/8 x 3 1/2	1 1/2	3/4	50/300
Z3832					20/200
3850		3/8 x 5	1 1/2	3/4	50/300
Z3850					20/200
3860		3/8 x 6	1 1/2	3/4	50/300
Z3860					10/200
1223		1/2 x 2 3/4	2	1	50/300
Z1223					10/200
1232		1/2 x 3 1/2	2	1	50/300
Z1232					10/200
1250		1/2 x 5	2	1	25/150
Z1250					10/100
1260		1/2 x 6	2	1	25/150
Z1260					10/100
1270		1/2 x 7	2	1	25/150
Z1270					10/1000
5832		5/8 x 3 1/2	3	1 1/4	25/150
Z5832					5/50
5842		5/8 x 4 1/2	3	1 1/4	25/150
Z5842					5/50
5850		5/8 x 5	3	1 1/4	20/120
Z5850					5/50
5860		5/8 x 6	3	1 1/4	15/90
Z5860					5/50
5870		5/8 x 7	3	1 1/4	15/90
Z5870					5/50
3440		3/4 x 4	3	1 1/2	18/108
Z3440					5/50
3450		3/4 x 5	3	1 1/2	12/72
Z3450					5/50
3460		3/4 x 6	3	1 1/2	12/72
Z3460					5/50
3470		3/4 x 7	3	1 1/2	10/60
Z3470					5/50
3482		3/4 x 8 1/2	3	1 1/2	10/30
Z3482					5/50
3410		3/4 x 10	3	1 1/2	10/30
7880		7/8 x 8	4 1/2	1 3/4	10/30
7810		7/8 x 10	4 1/2	1 3/4	10/30
7812		7/8 x 12	4 1/2	1 3/4	5/15
1080		1 x 8	5 1/2	2	10/30
1010		1 x 10	5 1/2	2	5/15
1012		1 x 12	5 1/2	2	5/15
Catalog Number	Anchor Carded	Anchor Diameter & Length (in)	Minimum Embedment (in)	Anchors Per Card	Quantity Cards Per Box/ Carton
DB1413		1/4 x 1 3/4	1	6	10/60
DB1423		1/4 x 2 3/4	1	6	10/60
DB1430		1/4 x 3	1	6	10/60
DB5620		5/16 x 2	1 1/4	6	10/60
DB5630		5/16 x 3	1 1/4	4	10/60
DB3820		3/8 x 2	1 1/2	4	10/60
DB3823		3/8 x 2 3/4	1 1/2	4	10/60
DB3832		3/8 x 3 1/2	1 1/2	4	10/60
DB1223		1/2 x 2 3/4	2	4	5/30
DB1232		1/2 x 3 1/2	2	2	5/30

RECOMMENDED EDGE DISTANCE & SPACING

Anchor Diameter	Embedment Depth	Edge Distance Requirements	Spacing Requirements
1/4	1 1/8	1 31/32	3 15/16
1/4	1 1/2	2 5/8	5 1/4
5/16	1 1/4	2 3/16	4 3/8
5/16	1 3/4	3 1/16	6 1/8
3/8	1 1/2	2 5/8	5 1/4
3/8	4	3	6
1/2	2 1/4	3 15/16	7 7/8
1/2	5	3 3/4	7 1/2
5/8	3 1/2	6 1/8	12 1/4
5/8	4 3/4	8 5/16	16 5/8
3/4	3	5 1/4	10 1/2
3/4	7	5 1/4	10 1/2
7/8	4 1/2	7 7/8	15 3/4
7/8	7	7	14
1	5 1/2	9 5/8	19 1/4
1	7	7	14

EDGE DISTANCE AND SPACING REQUIREMENTS

Embedment (E) in Anchor Diameters	Spacing	Edge Distance
$E \leq 6d$ (shallow)	3.5E	1.75E
$6d \leq E \leq 8d$ (standard)	2.00E	1.00E
$8d \leq E$ (deep)	1.50E	0.75E

LENGTH SELECTION GUIDE

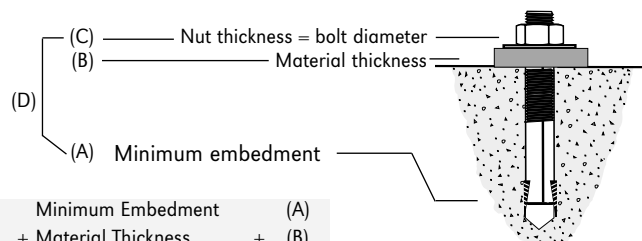

Minimum Embedment	(A)
+ Material Thickness	+ (B)
+ Bolt Diameter	+ (C)
= Total Anchor Length	= (D)

INSTALLATION INSTRUCTIONS

1. Drill the hole perpendicular to the work surface.* To assure full holding power, do not ream the hole or allow the drill to wobble.
2. Drill the hole deeper than the intended embedment of the anchor, but not closer than two anchor diameters to the bottom (opposite) surface of the concrete.
3. Clean the hole using compressed air and a nylon brush. A clean hole is necessary for proper performance.
4. Insert anchor into hole until washer rests solidly against fixture.
5. Tighten the nut 3 to 5 turns past the hand tight position.

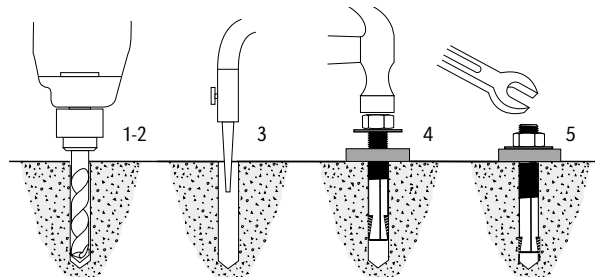

* **Always wear safety glasses.** Follow drill manufacturer's instructions. Use only solid carbide-tipped drill bits meeting ANSI B212.15 diameter standards as listed on back cover.



ANKR-TITE® Wedge Anchors



KEY FEATURES/BENEFITS

- **Will fit through a 1/16" larger pre-punched hole.**
- **Sets up fast.** Needs less rotation to achieve required torque.
- **Unique "Safety Shoulder" feature.** Supports clip when anchor is under strain, minimizes bolt-end collapse and/or clip slippage under ultimate loading conditions.
- **Enlarged dimples on clip.** Reduces slip, more responsive in lighter concrete
- **360° segment contact on clip.** Equalizes load distribution providing greater load performance carrying capacity and "more forgiving" design.
- **Custom sizes available.** 1/4" to 1 1/4" diameters available in zinc, galvanized and stainless steel.

SPECIFICATIONS, APPROVALS AND LISTINGS

TYPE

Zinc Plating	ASTM B-633, Type III, SCI
Galvanizing	ASTM A-153; B-454; B-695-82 and MIL-C-81562A with stainless steel clip.
ICC-ES Legacy Report	#1821
City of Los Angeles	#RR 24939
State DOT	Please call Customer Service for specific information by state.
Approvals	
Federal Specifications	QQZ-325Z, Type II, Class 3 (Clear Chromate added) FFS-325 Group II, Type 4, Class 1
Dade County	Acceptance #00-0328.02



MAXIMUM TENSILE AND SHEAR CAPACITY FOR STATIC LOADS

ZINC PLATED CARBON STEEL

Anchor & Hole Size	Embedment (in)	4000 psi		6000 psi	
		Tension (lbs)	Shear (lbs)	Tension (lbs)	Shear (lbs)
1/4	1 1/4	2000	2811	2042	2813
3/8	1 3/4	3165	3075	3165	3075
	4 5/8	4275	3075	5584	3075
1/2	2 1/2	6805	6260	8024	6260
	6 1/4	8249	7135	10713	7135
5/8	3 1/4	5180	9760	5057	6860
	6	12862	9760	16705	9760
3/4	3 3/4	12000	15860	12016	15860
	7 7/8	17756	23680	23060	23680
7/8	4	•	•	12016	•
1	4	13000	32494	13278	32494
	9	36171	32494	36171	32494
1 1/4	5 5/8	28733	•	28733	•
	10	50390	•	50390	•

CONCRETE FILLED STEEL DECK ULTIMATE TENSION & SHEAR (FT. LBS.)

Lower Flute of Steel Deck with Lightweight Concrete Fill*
f'c = 3,000 PSI

Anchor Dia. (in)	Install. Torque	Embed. Depth (in)	Tension (lbs)	Shear (lbs)
3/8	20-25	1 3/4	2414	4054
3/8		3	3169	
1/2	50-55	2 1/2	3458	5038
1/2		4	4274	
5/8	90-95	3 1/4	4199	5884
5/8		5	5036	
3/4	*	3 3/4	5136	8030
3/4		5 1/2	7711	

*Available upon request

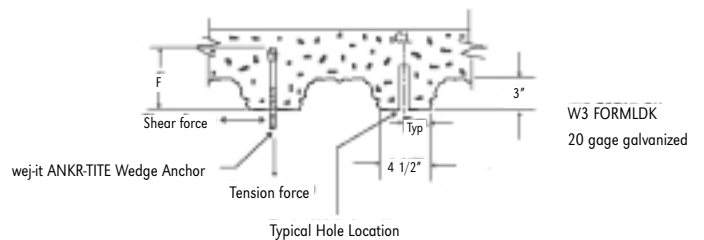

E=Embedment depth in inches (S1; 1 inch = 25.4 mm)

NOTES:

- Information provided only for the use of a qualified design engineer. Use of technical data by persons not qualified could cause serious damage, injury, or even death.
- Ultimate values shown. For static loads, use one-fourth of the maximum tensile and shear capacities for the recommended 4:1 safety factor.
- Tested to ASTM E-488 Test Standard.
- Sources (available upon request): 1) U.S. Testing Co., Tulsa, OK

RECOMMENDED EDGE DISTANCE & SPACING

Anchor Diameter	Embedment Depth	Edge	
		Distance Requirements	Spacing Requirements
1/4	1 1/4	2 1/4	4 3/8
1/4	2 7/8	2 1/8	4 3/8
3/8	1 3/4	3 1/8	6 1/8
3/8	4 5/8	3 1/2	7
1/2	2 1/8	3 3/4	7 1/2
1/2	2 1/2	4 3/8	8 3/4
1/2	6 1/4	4 1/2	9 3/8
5/8	2 5/8	4 1/2	9
5/8	3 1/4	5 1/2	11 3/8
5/8	6	4 1/2	9
3/4	3 1/4	5 1/2	11 3/8
3/4	3 3/4	6 1/2	13 1/8
3/4	7 7/8	6	12
7/8	3 7/8	6 3/4	13 1/2
7/8	8 5/8	6 1/2	13
1	4	7	14
1	10 1/2	7 7/8	15 3/4

EDGE DISTANCE AND SPACING REQUIREMENTS

Embedment (E) in Anchor Diameters	Spacing	Edge Distance
$E \leq 6d$ (shallow)	3.5E	1.75E
$6d \leq E \leq 8d$ (standard)	2.00E	1.00E
$8d \leq E$ (deep)	1.50E	0.75E

LENGTH SELECTION GUIDE

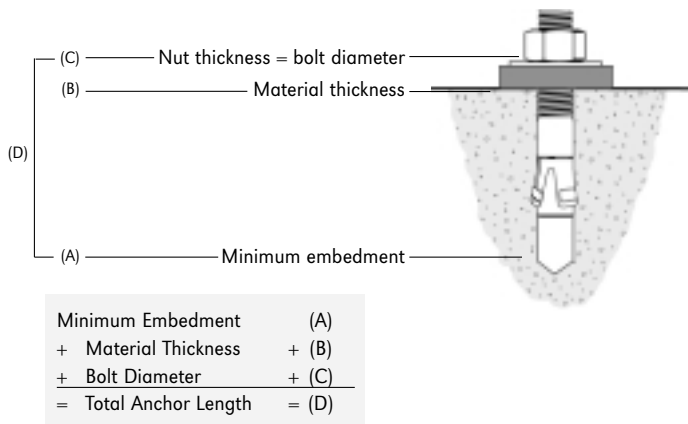

TORQUE VALUES

Anchor Diameter (in)	Recommended Setting Torque (ft lb)		W/O Inspection Turns To Set
	for Zinc & Galvanized	Recommended Setting Torque (ft lb) Stainless Steel	
1/4	6-8	4-7	3-5
3/8	20-25	20-25	3-5
1/2	50-55	40-50	3-5
5/8	90-95	80-90	3-5
3/4	165-175	145-155	3-5
7/8	240-250	N/A	3-5
1	290-300	250-275	3-5

LENGTH IDENTIFICATION CODES

Code	Length of Anchor
A	1 1/2 < 2
B	2 < 2 1/2
C	2 1/2 < 3
D	3 < 3 1/2
E	3 1/2 < 4
F	4 < 4 1/2
G	4 1/2 < 5
H	5 < 5 1/2
I	5 1/2 < 6
J	6 < 6 1/2
K	6 1/2 < 7
L	7 < 7 1/2
M	7 1/2 < 8
N	8 < 8 1/2
O	8 1/2 < 9
P	9 < 9 1/2
Q	9 1/2 < 10
R	10 < 11
S	11 < 12
T	12 < 13
U	13 < 14
V	14 < 15
W	15 < 16
X	16 < 17
Y	17 < 18
Z	18 < 19

INSTALLATION INSTRUCTIONS

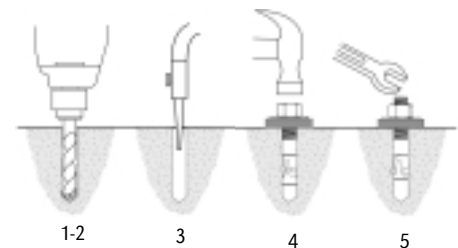

1. Drill the hole, whose diameter equals the anchor diameter perpendicular to the work surface. To assure full holding power, do not ream the hole or allow the drill to wobble.*
2. Drill the hole deeper than the intended embedment, but not closer than two diameters to the bottom (opposite) surface of the concrete.
3. A clean hole is necessary for proper performance. Clean the hole using a nylon brush and compressed air.
4. Assemble the nut and washer so that the top of the nut is flush with the top of the anchor. Drive the anchor through the material to be fastened so that the nut and washer are flush with the surface of the material.
5. Tighten the nut, or head, 3 to 5 turns past the hand tight position. Installing the "ANKR-TITE® Series" of anchors with a torque wrench is recommended for optimum performance. Refer to adjacent chart.

* **Always wear safety glasses.** Follow drill manufacturer's instructions. Use only solid carbide-tipped drill bits meeting ANSI B212.15 diameter standards.

ORDER INFORMATION

Carbon Steel		Stainless Steel		Anchor	Minimum	Thread	Quantity	
Zinc Plated	Galvanized	303/302HQ	316	Diameter & Length (in)	Embedment (in)	Length (in)	Box/Carton	Bulk
AT1413	ATG1413*	ATS1413		1/2 x 1 3/4	1 1/4	5/8	100/800	4000
ZAT1413	ZATG1413	ZATS1413					20/400	
AT1421	ATG1421*	ATS1421	ATSS1421	1/4 x 2 1/4	1 1/4	1	100/800	2000
ZAT1421	ZATG1421	ZATS1421	ZATSS1421				20/400	
AT1431	ATG1431*	ATS1431	ATSS1431	1/4 x 3 1/4	1 1/4	1	100/800	2000
ZAT1431	ZATG1431	ZATS1421	ZATSS1421				20/400	
AT3821	ATG3821	ATS3821	ATSS3821	3/8 x 2 1/4	1 3/4	1	50/400	1200
ZAT3821	ZATG3821	ZATS3821	ATSS3821				20/400	
AT3823	ATG3823	ATS3823	ATSS3823	3/8 x 2 3/4	1 3/4	1	50/400	1200
ZAT3823	ZATG3823	ZATS3823	ZATSS3823				20/400	
AT3830	ATG3830	ATS3830	ATSS3830	3/8 x 3	1 3/4	1 1/4	50/400	1000
ZAT3830	ZATG3830	ZATS3830	ZATSS3830				20/400	
AT3833	ATG3833	ATS3833	ATSS3833	3/8 x 3 3/4	1 3/4	2	50/400	500
ZAT3833	ZATG3833	ZATS3833	ZATSS3833				20/400	
AT3850	ATG3850	ATS3850		3/8 X 5	1 3/4	1 1/4	50/400	500
ZAT3850	ZATG3850	ZATS3850					20/200	
AT1223	ATG1223	ATS1223	ATSS1223	1/2 x 2 3/4	2 1/8	1 1/8	25/200	500
ZAT1223	ZATG1223	ZATS1223	ZATSS1223				10/200	
AT1233	ATG1233	ATS1233	ATSS1233	1/2 x 3 3/4	2 1/8	1 1/2	25/200	500
ZAT1233	ZATG1233	ZATS1233	ZATSS1233				10/200	
AT1241	ATG1241	ATS1241	ATSS1241	1/2 x 4 1/4	2 1/8	2	25/200	400
ZAT1241	ZATG1241	ZATS1241	ZATSS1241				10/200	
AT1242	ATG1242	ATS1242	ATSS1242	1/2 x 4 1/2	2 1/8	2	25/200	400
ZAT1242	ZATG1242	ZATS1242	ZATSS1242				10/200	
AT1252	ATG1252	ATS1252	ATSS1252	1/2 x 5 1/2	2 1/8	3 1/4	25/150	300
ZAT1252	ZATG1252	ZATS1252	ZATSS1252				10/200	
AT1270	ATG1270	ATS1270		1/2 x 7	2 1/8	3 1/2	25/150	250
ZAT1270	ZATG1270	ZATS1270					10/200	
AT5832	ATG5832	ATS5832		5/8 x 3 1/2	2 5/8	1 5/16	10/80	400
ZAT5832	ZATG5832	ZATS5832					5/50	
AT5841	ATG5841	ATS5841	ATSS5841	5/8 x 4 1/4	2 5/8	2	10/80	250
ZAT5841	ZATG5841	ZATS5841	ZATSS5841				5/50	
AT5850	ATG5850	ATS5850	ATSS5850	5/8 x 5	2 5/8	2 3/4	10/80	250
ZAT5850	ZATG5850	ZATS5850	ZATSS5850				5/50	
AT5860	ATG5860	ATS5860	ATSS5860	5/8 x 6	2 5/8	3 1/2	10/80	200
ZAT5860	ZATG5860	ZATS5860	ZATSS5860				5/50	
AT5870	ATG5870	ATS5870		5/8 x 7	2 5/8	3 1/2	10/80	100
ZAT5870	ZATG5870	ZATS5870					5/50	
AT5882	ATG5882	ATS5882		5/8 x 8 1/2	2 5/8	3 1/2	10/40	100
ZAT5882	ZATG5882	ZATS5882					5/50	
AT5810				5/8 x 10	2 5/8	3 1/2	10/40	100
AT3441	ATG3441	ATS3441		3/4 x 4 1/4	3 1/4	1 1/2	10/80	150
ZAT3441	ZATG3441	ZATS3441					5/50	
AT3443	ATG3443	ATS3443	ATSS3443	3/4 x 4 3/4	3 1/4	2	10/80	150
ZAT3443	ZATG3443	ZATS3443	ZATSS3443				5/50	
AT3452	ATG3452	ATS3452	ATSS3452	3/4 x 5 1/2	3 1/4	2 3/4	10/60	150
ZAT3452	ZATG3452	ZATS3452	ZATSS3452				5/50	
AT3461	ATG3461	ATS3461		3/4 x 6 1/4	3 1/4	3 1/2	10/60	
ZAT3461	ZATG3461	ZATS3461					5/50	
AT3470	ATG3470	ATS3470	ATSS3470	3/4 x 7	3 1/4	3 1/2	10/60	100
ZAT3470	ZATG3470	ZATS3470	ZATSS3470				5/50	
AT3482	ATG3482	ATS3482	ATSS3482	3/4 x 8 1/2	3 1/4	3 1/2	10/40	75
ZAT3482	ZATG3482	ZATS3482	ZATSS3482				5/50	
AT3410	ATG3410	ATS3410		3/4 x 10	3 1/4	3 1/2	10/40	75
AT3412	ATG3412*			3/4 x 12	3 1/4	3 1/2	5/20	
AT7860	ATG7860*			7/8 x 6	3 7/8	2 5/8	5/30	70
AT7880	ATG7880*			7/8 x 8	3 1/4	3	5/20	50
AT7810	ATG7810*			7/8 x 10	3 7/8	3	5/20	50
AT1060	ATG1060*	ATS1060		1 x 6	4	2 1/4	5/30	70
AT1090	ATG1090*	ATS1090		1 x 9	4	3	5/20	50
AT1012	ATG1012*	ATS1012		1 x 12	4	3	5/30	40
AT11490	ATG11490			1 1/4 x 9	6 1/4	3	4/16	
AT11412	ATG11412			1 1/4 x 12	6 1/4	3	4/16	

Catalog Number	Anchor	Minimum	Quantity
Carded	Diameter	Embedment	Cards Per
Drill Bit Included	& Length (in)	(in)	Box/Carton
DBAT1413	1/4 x 1 3/4	1 1/4	6
DBAT1421	1/4 x 2 1/4	1 1/4	6
DBAT1431	1/4 x 3 1/4	1 1/4	6
DBAT3821	3/8 x 2 1/4	1 3/4	4
DBAT3823	3/8 x 3 3/4	1 3/4	4
DBAT3830	3/8 x 3	1 3/4	4
DBAT1223	1/2 x 2 3/4	2 1/8	4

*Contact Customer Service for box/carton quantities

Center Pin Drive Anchors



KEY FEATURES/BENEFITS

- **Easy to install** – just hammer the center pin and it's set. Anchor tensions itself automatically, so no wrench is needed.
- **Visually inspectable** – anchor is set when center pin is flush with top of hole.
- **Depth of hole not critical** – no depth gauge required.
- **No templates required** – the actual diameter of the anchor is the same as its nominal diameter.
- **Yellow dichromate finish** for superior corrosion resistance.

SPECIFICATIONS, APPROVALS AND LISTINGS

TYPE	
ICC LEGACY REPORT	ER 5045
Federal Specifications	QQZ-325Z, TYPE II CLASS 3 (YELLOW DICHROMATE ADDED) FFS-325 GROUP II TYPE 4 CLASS I

MAXIMUM TENSILE & SHEAR CAPACITY FOR STATIC LOADS

Anchor Diameter	Embedment Depth	2000 psi	
		Tension	Shear
1/4	1 1/8	780	1000
5/16	1 1/2	2130	1320
3/8	1 7/8	2530	2580
1/2	2 1/2	4040	4920
5/8	2 3/4	6360	

EDGE DISTANCE AND SPACING REQUIREMENTS

Embedment (E) in Anchor Diameters	Spacing	Edge Distance
$E \leq 6d$ (shallow)	3.5E	1.75E
$6d \leq E \leq 8d$ (standard)	2.00E	1.00E
$8d \leq E$ (deep)	1.50E	0.75E

ORDER INFORMATION

Catalog Number	Anchor Diameter & Length	Maximum Thickness Fastened	Minimum Embedment	Box Qty
CP1413	1/4 x 1 3/4	3/8	1 1/8	100
CP1423	1/4 x 2 3/8	1	1 1/8	100
CP5620	5/16 x 2	5/16	1 3/8	100
CP5623	5/16 x 2 3/4	11/16	1 3/4	100
CP3823	3/8 x 2 3/8	5/8	1 3/8	50
CP3832	3/8 x 3 1/2	1 3/8	1 3/4	50
CP3843	3/8 x 4 3/4	2 5/8	1 3/4	50
CP1223	1/2 x 2 3/4	1/4	2	25
CP1232	1/2 x 3 1/2	3/4	2 1/4	25
CP1243	1/2 x 4 3/4	2	2 1/4	25
CP1260	1/2 x 6	3 1/4	2 1/4	25
CP5840	5/8 x 4	5/8	2 3/4	10

INSTALLATION INSTRUCTIONS

1. Drill the hole perpendicular to the work surface. To assure full holding power, do not ream the hole or allow drill to wobble.* Clean hole using compressed air and a nylon brush. A clean hole is necessary for proper performance.
2. Preset the nut and washer for desired embedment.
3. Hammer center pin until it is aligned with the top of the bolt.
4. Tighten nut.

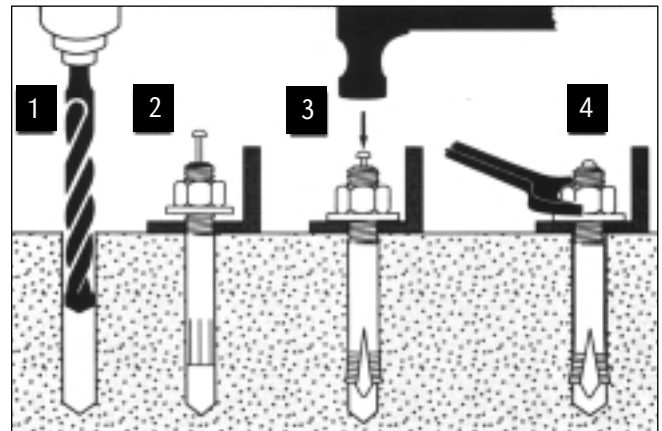

* Always wear safety glasses. Follow drill manufacturer's instructions. Use only solid carbide-tipped drill bits meeting ANSI B212.15 diameter standards.

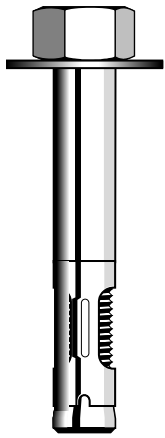

Sleeve Anchors

KEY FEATURES/BENEFITS

- **Fully Assembled and Ready to Use.** Speeds installation and eliminates the problem of missing components.
- **Suitable for Wide Variety of Applications.**
- **Available in a variety of head styles** to meet all your anchoring needs.
- **Usable in Multiple Masonry Substrates.** Poured concrete, grouted blocks, brick, horizontal mortar joints and hollow concrete blocks.

SPECIFICATIONS, APPROVALS AND LISTINGS

TYPE	
Zinc Plating	ASTM B-633
City of Los Angeles	#RR 24939
Federal Specifications	QQZ-325C, Type II, Class 3 (Clear Chromate added) FFS-325, Group II, Type 3, Class 3

MAXIMUM TENSILE AND SHEAR GUIDELINES

For Static Loads in Concrete

Anchor Size (in)	Head Style	Drill Diameter (in)	Bolt Size (in)	4000 psi		
				Embedment (in)	Tension (lbs)	Shear (lbs)
1/4	Acorn	1/4	10-24	1 1/16	1049	1379
1/4		1/4	10-24	1 11/16	1493	1774
1/4	Flat Head	1/4	10-24	1 5/8	1393	1141
1/4		1/4	10-24	2 5/8	1470	1243
1/4	Round Head	1/4	10-24	1 1/2	2094	1328
1/4		1/4	10-24	2 1/2	1456	1379
5/16	Hex Nut	5/16	1/4-20	1 3/16	1630	2225
5/16		5/16	1/4-20	2 1/16	2181	2311
3/8	Hex Nut	3/8	5/16-18	1 1/4	2502	3116
3/8		3/8	5/16-18	2 1/2	3046	3691
3/8	Flat Head	3/8	5/16-18	2 3/8	2928	2318
3/8		3/8	5/16-18	3 11/16	2345	1954
3/8		3/8	5/16-18	4 5/8	2563	2064
3/8		3/8	5/16-18	5 5/8	2842	2238
3/8	Round Head	3/8	5/16-18	2	3019	2091
1/2	Hex Nut	1/2	3/8-16	1 1/2	2656	3724
1/2		1/2	3/8-16	2 3/8	4649	2726
1/2		1/2	3/8-16	3 3/8	5127	4726
5/8	Hex Nut	5/8	1/2-13	2 1/4	4568	5218
5/8		5/8	1/2-13	3 15/16	7285	6747
5/8		5/8	1/2-13	5 7/16	7631	7689
3/4	Hex Nut	3/4	5/8-11	1 7/8	5388	7862
3/4		3/4	5/8-11	3 9/16	6219	9786
3/4		3/4	5/8-11	5 1/2	6456	10073

For Static Loads in Hollow Concrete Block

Anchor Size (in)	Head Style	Drill Diameter (in)	Bolt Size (in)	2000 psi Hollow Concrete Block				
				Embedment (in)	w/o 2000 psi grout Tension (lbs)	Shear (lbs)	w/ 2000 psi grout Tension (lbs)	Shear (lbs)
1/4	Acorn	1/4	10-24	1 1/16	943	1587	1476	1587
1/4		1/4	10-24	1 5/8	1065	2265	1346	1518
5/16		5/16	1/4-20	2 1/16	1127	3056	1479	2265
3/8	Hex Nut	3/8	5/16-18	1 1/4	891	3009	2311	3056
3/8		3/8	5/16-18	2 1/2	625	3794	2218	3009
1/2	Hex Nut	1/2	3/8-16	1 1/2	973	4071	2094	3794
1/2		1/2	3/8-16	2 3/8	•	•	2689	4071
1/2		1/2	3/8-16	3 3/8	•	•	2816	5197
5/8	Hex Nut	5/8	1/2-13	3 15/16	•	•	4098	6580
5/8		5/8	1/2-13	5 7/16	•	•	4432	6617
3/4	Hex Nut	3/4	5/8-11	3 9/16	•	•	4990	9888
3/4		3/4	5/8-11	5 1/2	•	•	4699	9924

Source (available on request): SGS U.S. Testing Co. Inc., Tulsa, OK; 1996 (Tested in accordance with ASTM E-488).

LENGTH SELECTION GUIDE

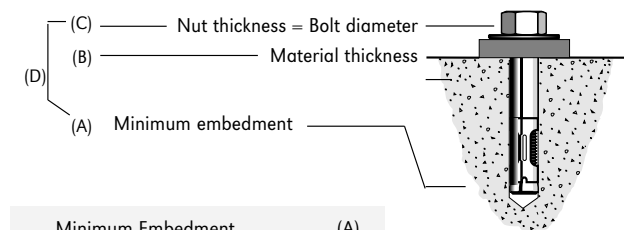

Minimum Embedment	(A)
+ Material Thickness	+ (B)
+ Bolt Diameter	+ (C)
= Total Anchor Length	= (D)

EDGE DISTANCE AND SPACING REQUIREMENTS

Embedment (E) in Anchor Diameters	Spacing	Edge Distance
$E \leq 6d$ (shallow)	3.5E	1.75E
$6d \leq E \leq 8d$ (standard)	2.00E	1.00E
$8d \leq E$ (deep)	1.50E	0.75E

ORDER INFORMATION

Catalog Number Carbon Steel Zinc Plated	Head Style	Anchor Diameter & Length (in)	Drill bit Size	Minimum Embedment (in)	Quantity	
					Box/ Carton	Bulk
ASA 1413	Acorn Nut	1/4 x 1 3/8	1/4	1 1/8	100/1000	2000
ZASA 1413					20/400	
ASA 1421	Acorn Nut	1/4 x 2 1/4	1/4	1 1/8	100/800	2000
ZASA 1421					20/400	
HSA 5612	Hex Head	5/16 x 1 1/2	5/16	1 1/4	100/800	2000
ZHSA 5612					20/400	
HSA 5622	Hex Head	5/16 x 2 1/2	5/16	1 1/4	100/800	1000
ZHSA 5622					20/400	
HSA 3813	Hex Head	3/8 x 1 7/8	3/8	1 1/2	50/400	900
ZHSA 3813					20/400	
HSA 3830	Hex Head	3/8 x 3	3/8	1 1/2	50/400	500
ZHSA 3830					20/400	
HSA 1221	Hex Head	1/2 x 2 1/4	1/2	1 7/8	25/200	500
ZHSA 1221					10/200	
HSA 1230	Hex Head	1/2 x 3	1/2	1 7/8	25/200	400
ZHSA 1 230					10/200	
HSA 1240	Hex Head	1/2 x 4	1/2	1 7/8	25/200	300
ZHSA 1240					10/200	
HSA 1260	Hex Head	1/2 x 6	1/2	1 7/8	25/200	200
ZHSA 1260					10/200	
HSA 5821	Hex Head	5/8 x 2 1/4	5/8	2	25/200	300
ZHSA 5821					5/100	
HSA 5830	Hex Head	5/8 x 3	5/8	2	25/200	300
ZHSA 5830					5/100	
HSA 5841	Hex Head	5/8 x 4 1/4	5/8	2	10/80	150
ZHSA 5841					5/50	
HSA 5860	Hex Head	5/8 x 6	5/8	2	10/80	100
ZHSA 5860					5/50	
HSA 3422	Hex Head	3/4 x 2 1/2	3/4	2 1/4	10/80	300
ZHSA 3422					5/50	
HSA 3440	Hex Head	3/4 x 4	3/4	2 1/4	10/80	200
ZHSA 3440					5/50	
HSA 3461	Hex Head	3/4 x 6 1/4	3/4	2 1/4	10/80	300
ZHSA 3461					5/50	
FSA 1421	Flat Head	1/4 x 2 1/4	1/4	1 1/8	100/800	
ZFSA 1421					20/400	
FSA 1431	Flat Head	1/4 x 3 1/4	1/4	1 1/8	100/800	
ZFSA 1431					20/400	
FSA 1440	Flat Head	1/4 x 4	1/4	1 1/8	100/800	
ZFSA 1440					20/400	
FSA 3823	Flat Head	3/8 x 2 3/4	3/8	1 1/2	50/400	
ZFSA 3823					10/200	
FSA 3840	Flat Head	3/8 x 4	3/8	1 1/2	50/400	
ZFSA 3840					10/200	
FSA 3850	Flat Head	3/8 x 5	3/8	1 1/2	50/400	
ZFSA 3850					10/200	
FSA 3860	Flat Head	3/8 x 6	3/8	1 1/2	50/400	
ZFSA 3860					10/200	
RSA 1420	Round Head	1/2 x 2	1/4	1 1/8	100/1000	2000
ZRSA 1420					20/400	
RSA 1430	Round Head	1/4 x 3	1/4	1 1/8	100/800	2000
ZRSA 1430					20/400	
RSA 3823	Round Head	3/8 x 2 3/4	3/8	1 1/2	50/500	
ZRSA 3823					10/200	
ZTSA 1421	Threshold	1/4 x 2 1/4	1/4	1 1/8	20/200	

Catalog Number Carded Drill Bit Included	Anchor Diameter & Length (in)	Minimum Embedment (in)	Quantity	
			Anchors Per Card	Cards Per Box/ Carton
DBSL5612	5/16 x 1 1/2	1 1/4	6	10/60
DBSL3813	3/8 x 1 7/8	1 1/2	4	10/60
DBSL3830	3/8 x 3	1 1/2	4	10/60
DBSL1221	1/2 x 2 1/4	1 7/8	4	10/60
DBSL1230	1/2 x 3	1 7/8	4	10/60

AVAILABLE HEAD STYLES

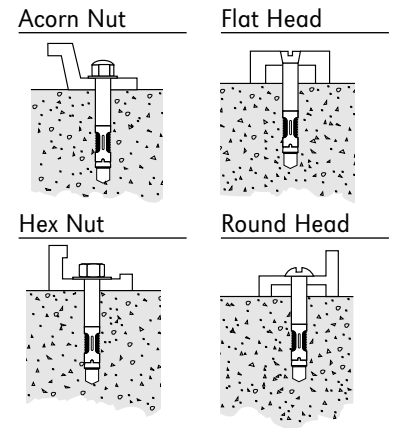

INSTALLATION INSTRUCTIONS

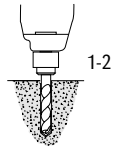
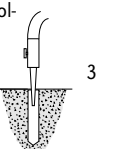
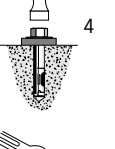
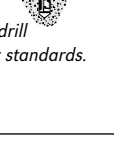
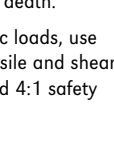
1. Drill the hole perpendicular to the work surface.* To assure full holding power, do not ream the hole or allow the drill to wobble. 
2. Drill the hole deeper than the intended embedment of the anchor, but not closer than two anchor diameters to the bottom (opposite) surface of the concrete. Through drilling is allowed when using sleeve anchors in hollow concrete block. 
3. Clean the hole using compressed air and a nylon brush. A clean hole is necessary for proper performance. 
4. Assemble the washer and nut on the anchor so that the nut protrudes slightly beyond the fixture and into the hole making sure the nut, or head, rests solidly against the fixture. 
5. Tighten the nut, or head, 3 to 5 turns past the hand tight position. 

* **Always wear safety glasses.**
Follow drill manufacturer's instructions. Use only solid carbide-tipped drill bits meeting ANSI B212.15 diameter standards.

NOTES:

- Information provided only for the use of a qualified design engineer. Use of technical data by persons not qualified could cause serious damage, injury or even death.
- Ultimate values shown. For static loads, use one-fourth of the maximum tensile and shear capacities for the recommended 4:1 safety factor.



POWER-Drop® Drop-In Anchors



KEY FEATURES/BENEFITS

- **Internally Threaded.** Wedge anchor performance with the convenience of a drop-in.
- **Safety Shoulder.** Supports clip when anchor is under strain, eliminating bolt-end collapse and/or clip slippage under ultimate loading conditions.
- **ICC Seismic approved.** Allowable values may be increased 33 1/3 percent for short-term loading in resisting earthquake or wind loads.
- **Numerous Head-Style Options.** May be used with machine screws, tamperproof bolts, threaded rod and a variety of other male-threaded fasteners.
- **Available in a variety of sizes and materials.** Zinc and Stainless Steel. Ranging from 3/8" to 1" bolt diameters.

SPECIFICATIONS, APPROVALS AND LISTINGS

TYPE	
Zinc Plating	ASTM B-633, Type III, SCI
ICC-ES Legacy Report	#5063

MAXIMUM TENSILE CAPACITY FOR STATIC LOADS

(Allowable Loads in 3000 PSI Stone Aggregate Concrete)

Catalog No.	Bolt Diameter	Anchor Dimensions	Min. Hole Depth	Installation Turns	Drill Diameter	Recess	Tension (Lbs)	Shear (Lbs)
PD-38	3/8	1/2 X 2-5/16	3	6	1/2	5/16	5840	4200
PD-12	1/2	5/8 X 3-3/32	4	5	5/8	3/8	10352	7320
PD-58	5/8	7/8 X 3-13/16	5-1/2	4	7/8	1/2	14800	11880
PD-34	3/4	1 X 4-5/8	6	3-3/4	1	5/8	15800	13360
PD-1	1	1 1/4 x 5	6 1/2	3	1 1/4	3/4	24752	26440

RECOMMENDED SPACING AND EDGE DISTANCE REQUIREMENTS

Anchor Diameter (in.)	Embedment Depth	Minimum Edge Distance	Tension Load Factor for Min. Edge Distance	Shear Load Factor for Min. Edge Distance	Minimum Spacing	Tension Load Factor for Minimum Spacing	Shear Load Factor for Minimum Spacing
3/8	2 5/8	2 5/8	0.7	0.5	2 5/8	0.5	0.4
1/2	3 1/2	3 1/2	0.7	0.5	3 1/2	0.5	0.4
5/8	4 3/8	4 3/8	0.7	0.5	4 3/8	0.5	0.4
3/4	5 1/4	5 1/4	0.7	0.5	5 1/4	0.5	0.4
1	5 3/4	5 3/4	0.7	0.5	5 3/4	0.35	0.4

ORDER INFORMATION

Catalog Number

Carbon Steel Zinc Plated	Bolt Size	Dimensions (in)	Thread Depth	Quantity Box/Carton
PD-38	3/8	1/2 x 2 5/16	1 3/16	25/200
PD-12	1/2	5/8 x 3 3/32	1 11/16	10/80
PD-58	5/8	7/8 x 3 13/16	1 7/8	5/30
PD-34	3/4	1 x 4 5/8	1 29/32	5/30
PD-1	1	1 1/4 x 5	1 51/64	5/30

Note — One Setting Tool Included Per Box

PDST38	3/8	3/8 x 3
PDST12	1/2	1/2 x 3 1/2
PDST58	5/8	5/8 x 4
PDST34	3/4	3/4 x 4 1/2
PDST1	1	1 x 4 1/2

* **Always wear safety glasses.** Follow drill manufacturer's instructions. Use only solid carbide-tipped drill bits meeting ANSI B212.15 diameter standards.

INSTALLATION INSTRUCTIONS

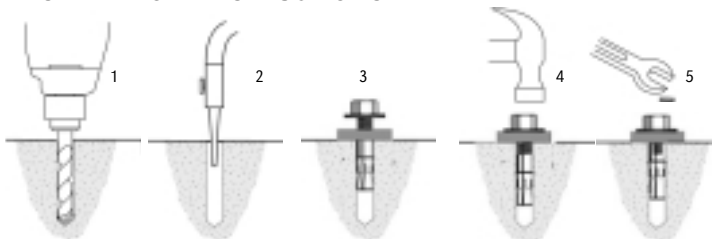

1. Drill the hole perpendicular to the work surface. Do not ream the hole or allow the drill to wobble. Drill the hole to the minimum hole depth.*
2. Thoroughly clean hole using compressed air and a nylon brush. An uncleaned hole can significantly compromise anchor performance.
3. Thread the cap screw with washer* into the threaded end of the anchor. Adjust the position of the cap screw and washer to achieve the Initial Embedment shown in the table between the bottom of the anchor and the bottom of the washer.
4. After the cap screw and washer position is set, place the anchor in the hole and hammered downward until the washer is in contact with the surface of the concrete.
5. Rotate the cap screw in a clockwise direction, four complete revolutions. This procedure has been calculated to give the final embedment listed in the table.

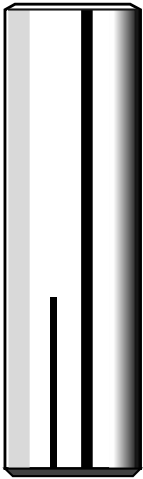

Drop-In Anchors

KEY FEATURES/BENEFITS

- **Ideal for Overhead Applications.** Requires relatively shallow embedment and eliminates requirement for rod couplings when threaded rod is dropped from ceiling.
- **Highly Dependable.** Complete anchor setting is assured; simply drive the internal expander plug home with a hammer or mallet.

SPECIFICATIONS, APPROVALS AND LISTINGS

TYPE	
Zinc Plating	ASTM B-633 Type III, SCI (Clear Chromate added)
Federal Specifications	FFS-325, Group VIII, Type I
Underwriters Laboratory	File #EX 3875

EDGE DISTANCE AND SPACING REQUIREMENTS

Embedment (E) in Anchor Diameters (d)	Spacing	Edge Distance
$E < 6d$ (shallow)	3.50E	1.75E
$6d \leq E \leq 8d$ (standard)	2.00E	1.00E
$8d < E$ (deep)	1.50E	0.75E



WDM 38

Mini Drop-In Anchor

KEY FEATURES/BENEFITS

- **Ideal for hollow core, precast and post tension slabs.**

MAXIMUM TENSILE AND SHEAR GUIDELINES FOR STATIC LOADS

Catalog Number Carbon	Anchor Thread Diameter (in)	Drill Diameter (in)	Embedment Depth (in)	Unreinforced Stone Aggregate Concrete 4000 psi	
				Tension (lbs)	Shear (lbs)
WD14	1/4	3/8	1	2629	1709
WDM38	3/8	1/2	3/4	2230	2903
WD38	3/8	1/2	1 5/8	4165	2889
WD12	1/2	5/8	2	7114	5060
WD58	5/8	7/8	2 1/2	8571	8263
WD34	3/4	1	3 1/4	12971	11760

ORDER INFORMATION

Catalog Number Carbon	Setting Tool		Anchor Thread Size (in)	Anchor Diameter & Length (in)	Quantity Box/ Carton
	Stainless Steel	Setting Tool			
WD14	WDS14	ST14	1/4	3/8 x 1	100/1000
WDM38	•	STM38	3/8	1/2 x 3/4	50/500
WD38	WDS38	ST38	3/8	1/2 x 1 5/8	50/500
WD12	WDS12	ST12	1/2	5/8 x 2	50/500
WD58	•	ST58	5/8	7/8 x 2 1/2	25/200
WD34	•	ST34	3/4	1 x 3 1/4	25/150

NOTES:

- Source (Available on request): SGS U.S. Testing Co., Inc., Tulsa, OK; 1996.

INSTALLATION INSTRUCTIONS

1. Select the proper size drill bit from the Maximum Tensile chart. Drill the hole perpendicular to the work surface.* To assure full holding power, do not ream the hole or allow the drill to wobble.
2. Drill the hole at least as deep as the full length of the anchor, but not closer than two anchor diameters to the bottom (opposite) surface of the concrete.
3. Clean the hole using compressed air and a nylon brush.
4. Tap the anchor, threaded portion last, into the hole. Make sure that the top of the anchor is flush with, or below, the level of the work surface.

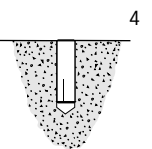
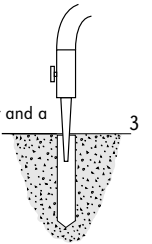
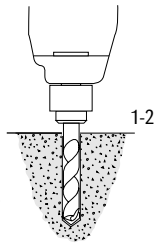

5. Using only a setting tool, insert the setting tool into the threaded end of the anchor and expand the anchor by striking the end of the setting tool with a hammer. The anchor is set (fully expanded) when the shoulder of the **wej-it**® setting tool touches the **wej-it**® anchor. Full expansion is necessary for proper anchor performance.

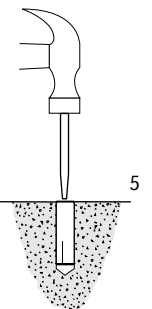

* **Always wear safety glasses.** Follow the drill manufacturer's safety instructions. Use only solid carbide-tipped drill bits meeting ANSI B212.15 diameter standards as listed on back cover.

Concrete Screws



KEY FEATURES/BENEFITS

- Cut threads in structural concrete, hollow block, brick, mortar, concrete masonry units and many others.
- Step thread design:
 - Increases ease of installation
 - Increases pullout values
- No sleeve or shield required.
- Taps its own thread
- Drill bit included in each box.

SPECIFICATIONS, APPROVALS AND LISTINGS

TYPE	
ICC-ES Legacy Report	#5045
Zinc Plated	
CR-10 Coating	

ORDER INFORMATION

Catalog Number	Anchor Diameter & Length	Head Style	Drill Diameter	Quantity Box/Carton
FCS3611	3/16 x 1 1/4	Phillips Flat	5/32	100/1000
FCS3613	3/16 x 1 3/4	Phillips Flat	5/32	100/1000
FCS3621	3/16 x 2 1/4	Phillips Flat	5/32	100/1000
FCS3623	3/16 x 2 3/4	Phillips Flat	5/32	100/1000
FCS3631	3/16 x 3 1/4	Phillips Flat	5/32	100/1000
FCS3633	3/16 x 3 3/4	Phillips Flat	5/32	100/1000
FCS3640	3/16 x 4	Phillips Flat	5/32	100/1000
FCS1411	1/4 x 1 1/4	Phillips Flat	3/16	100/1000
FCS1413	1/4 x 1 3/4	Phillips Flat	3/16	100/1000
FCS1421	1/4 x 2 1/4	Phillips Flat	3/16	100/1000
FCS1423	1/4 x 2 3/4	Phillips Flat	3/16	100/1000
FCS1431	1/4 x 3 1/4	Phillips Flat	3/16	100/1000
FCS1433	1/4 x 3 3/4	Phillips Flat	3/16	100/1000
FCS1440	1/4 x 4	Phillips Flat	3/16	100/1000
FCS1450	1/4 x 5	Phillips Flat	3/16	100/1000
HCS3611	3/16 x 1 1/4	Hex Combo	5/32	100/1000
HCS3613	3/16 x 1 3/4	Hex Combo	5/32	100/1000
HCS3621	3/16 x 2 1/4	Hex Combo	5/32	100/1000
HCS3623	3/16 x 2 3/4	Hex Combo	5/32	100/1000
HCS3631	3/16 x 3 1/4	Hex Combo	5/32	100/1000
HCS3633	3/16 x 3 3/4	Hex Combo	5/32	100/1000
HCS1411	1/4 x 1 1/4	Hex Combo	3/16	100/1000
HCS1413	1/4 x 1 3/4	Hex Combo	3/16	100/1000
HCS1421	1/4 x 2 1/4	Hex Combo	3/16	100/1000
HCS1423	1/4 x 2 3/4	Hex Combo	3/16	100/1000
HCS1431	1/4 x 3 1/4	Hex Combo	3/16	100/1000
HCS1433	1/4 x 3 3/4	Hex Combo	3/16	100/1000
HCS1440	1/4 x 4	Hex Combo	3/16	100/1000
HCS1450	1/4 x 5	Hex Combo	3/16	100/1000
HCS1440	1/4 x 4	Hex Combo	3/16	100/1000
HCS1450	1/4 x 5	Hex Combo	3/16	100/1000
CSDT Drive Tool Kit				1

MAXIMUM TENSILE AND SHEAR CAPACITY FOR STATIC LOADS

Anchor Diameter	Embedment Depth	2500 psi	
		Tension lbs.	Shear lbs.
1/4	1 1/2	1600	1920
1/4	1	760	1360
3/16	1 1/2	1600	1360
3/16	1	760	1320

RECOMMENDED EDGE DISTANCE & SPACING

Anchor Diameter	Embedment Depth	Edge	
		Distance Requirements	Spacing Requirements
1/4	1 1/2	2 1/4	4 1/2
1/4	1	1 1/2	3
3/16	1 1/2	2 1/4	4 1/2
3/16	1	1 1/2	3

INSTALLATION INSTRUCTIONS

1. Using a carbide tip SDS or straight shank drill bit, predrill a hole a minimum of 1/2" deeper than fasteners embedment.*
2. Drive the fastener into the pilot hole.

* **Always wear safety glasses.** Follow drill manufacturer's instructions. Use only solid carbide-tipped drill bits meeting ANSI B212.15 diameter standards.

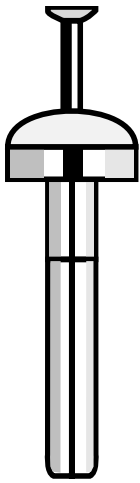

Drive Nails

KEY FEATURES/BENEFITS

- **Easy to install.**
- **Tamper proof.**
- **Can be used in concrete, block, brick or stone.**
- **Available in variety of head styles.** Mushroom head, flat head, round head.

MAXIMUM TENSILE GUIDELINES FOR STATIC LOADS

Catalog Number	Anchor Diameter & Length (in)	Drill Diameter (in)	Max. Thickness of Fixture (in)	Min. Embedment (in)	Unreinforced Stone
					Aggr. Concrete 3000 psi Tension (lbs)
DN3678	3/16 X 7/8	3/16	1/4	5/8	400
DN1403	1/4 X 3/4	1/4	1/8	5/8	500
DN1410	1/4 X 1	1/4	1/4	3/4	800
DN1411	1/4 X 1 1/4	1/4	1/2	3/4	800
DN1412	1/4 X 1 1/2	1/4	3/4	3/4	800
DN1420	1/4 X 2	1/4	1 1/4	3/4	800

ORDER INFORMATION

Catalog Number Carbon Steel	Head Style	Anchor Diameter & Length (in)	Industrial Pack Quantity	
			Box/Carton	Bulk
Zinc Plated				
DN3678	Mushroom	3/16 x 7/8	100/1000	
5DN3678				5000
DN1403	Mushroom	1/4 x 3/4	100/1000	
5DN1403				3000
DN1410	Mushroom	1/4 x 1	100/1000	
5DN1410				3000
DN1411	Mushroom	1/4 x 1 1/4	100/1000	
5DN1411				3000
DN1412	Mushroom	1/4 x 1 1/2	100/800	
5DN1412				1800
DN1420	Mushroom	1/4 x 2	100/800	
5DN1420				2000
Nylon				
DNN3610	Mushroom	3/16 x 1	100/1000	
DNN1403	Mushroom	1/4 x 3/4	100/1000	
DNN1410	Mushroom	1/4 x 1	100/1000	
5DNN1410				3000
DNN1412	Mushroom	1/4 x 1 1/2	100/800	
5DNN1412				2000
DNN1420	Mushroom	1/4 x 2	100/800	
5DNN1420				2000
DNN1430	Mushroom	1/4 x 3	100/800	
DNF3610	Flat	3/16 x 1	100/1000	
DNF3612	Flat	3/16 x 1 1/2	100/1000	
DNF1410	Flat	1/4 x 1	100/1000	
DNF1412	Flat	1/4 x 1 1/2	100/800	
DNF1420	Flat	1/4 x 2	100/800	
DNR3610	Round	3/16 x 1	100/1000	
DNR3612	Round	3/16 x 1 1/2	100/1000	
DNR1410	Round	1/4 x 1	100/1000	
DNR1412	Round	1/4 x 1 1/2	100/800	
DNR1420	Round	1/4 x 2	100/800	

*Always wear safety glasses. Follow the drill manufacturer's safety instructions. Use only solid carbide-tipped drill bits meeting ANSI B212.15 diameter standards as listed on back cover.

NOTES:

- CAUTION: Drive Nail Anchors are not recommended for structural or overhead applications.
- Information provided only for the use of a qualified design engineer. Use of technical data by persons not qualified could cause serious damage, injury or even death.
- Ultimate values shown. For static loads, use one-fourth of the maximum tensile and shear capacities for the recommended 4:1 safety factor.
- Source (available upon request): UES Technical Information.

SPECIFICATIONS

TYPE

Zinc Plating	ASTM B-633
Federal	FFS-325, Group V,
Specifications	Type 2, Class 2

AVAILABLE HEAD STYLES

Mushroom Head

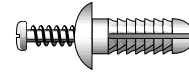

Flat Head



Round Head

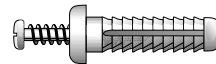

INSTALLATION INSTRUCTIONS

1. Drill hole in masonry or concrete through mounting holes in fixture same diameter as anchor to be used. In wood and other soft material to be fastened, drill through fixture and directly into masonry. (Drill hole 1/4" deeper than the calculated embedment depth.)*
2. Insert anchor assembly through mounting holes in fixture and into anchor hole.
3. Tap gently until head of anchor body is set tightly against item to be fastened.
4. Gently hammer pin flush to expand body. Do not over drive pin into body as this could damage the anchor.

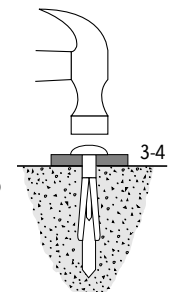
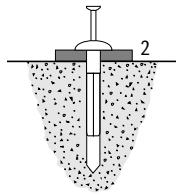
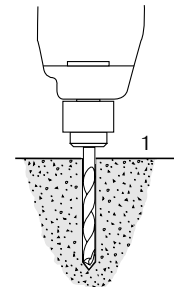



Single Expansion Shields

KEY FEATURES/BENEFITS

- Uses include fastening into rock, concrete and brick.
- Holding power unaffected if bolt is removed and replaced.
- One-piece design, made of zinc alloy, is entirely rust-proof.

SPECIFICATIONS, APPROVALS AND LISTINGS

TYPE

GSA Spec. FF-S-325, Group II, Type 2, Class 2, Style 1

ORDER INFORMATION

Catalog Number	Internal Diameter	Drill Diameter	Anchor Length	Quantity Box/Carton	3000 PSI	
					Maximum Tensile Strength	Maximum Shear Strength
SES14	1/4	1/2	1 5/16	100/1000	1800	2100
SES56	5/16	5/8	1 1/2	50/500	2000	3250
SES38	3/8	5/8	1 1/2	50/500	2200	3950
SES12	1/2	7/8	2	25/200	3500	8200
SES58	5/8	1	2 5/8	25/200	5050	13050

INSTALLATION INSTRUCTIONS:

1. Drill hole of recommended diameter (slightly deeper than length of shield).*
2. Clean the hole using compressed air and a nylon brush.
3. Install shield flush with surface of hole threaded side down.
4. Place fixture. Insert machine bolt through fixture into shield and tighten.
5. To determine length of bolt: thickness of fixture plus length of shield, equals length of bolt.



Double Expansion Shields

KEY FEATURES/BENEFITS

- Uses include fastening into rock, concrete, brick, etc.
- Eliminates high stress points detrimental in fastening into materials of medium hardness, has high gripping power and expands fully.
- Ideal for sheer loads or where bolt is subject to side pressure or vibration.
- Does not fracture, permits fastening at any length.

SPECIFICATIONS, APPROVALS AND LISTINGS

TYPE

GSA Spec. FF-S-325, Group II, Type 2, Class 2, Style 1

ORDER INFORMATION

Catalog Number	Internal Diameter	Drill Diameter	Anchor Length	Quantity Box/Carton	3000 PSI	
					Maximum Tensile Strength	Maximum Shear Strength
DES14	1/4	1/2	1 5/16	100/1000	1850	2780
DES56	5/16	5/8	1 1/4	50/500	2000	3600
DES38	3/8	3/4	1 1/2	50/400	3900	4485
DES12	1/2	7/8	2	25/200	4600	9300
DES58	5/8	1	2 1/4	25/200	5950	13250
DES34	3/4	1 1/4	2 7/8	10/80	9350	16200

INSTALLATION INSTRUCTIONS:

1. Drill hole of recommended diameter (slightly deeper than length of shield).*
2. Clean the hole using compressed air and a nylon brush.
3. Insert the shield into hole with threaded side down.
4. Shield should be flush or slightly below surface of masonry. Place fixture. Insert machine bolt and tighten.
5. A deep setting increases holding power of masonry. If desired, place a pipe sleeve between shield and fixture being attached.

*Always wear safety glasses. Follow the drill manufacturer's safety instructions. Use only solid carbide-tipped drill bits meeting ANSI B212.15 diameter standards as listed on back cover.

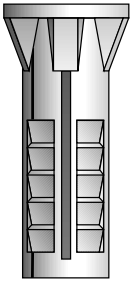

Lead Expansion Anchors

KEY FEATURES/BENEFITS

- Quick installation of lightweight fixtures in masonry and concrete
- Can be used with lag, wood or sheet metal screws
- Expands without turning
- Not affected by moisture or chemicals

ORDER INFORMATION

Catalog Number	Description	Screw Size x Anchor Length	Drill Diameter	Fractional Screw Size	Quantity	
					Box	Carton
LA0603	Lead expansion anchor	6-8 x 3/4	1/4	1/8 - 3/16	100	2000
LA0610	Lead expansion anchor	6-8 x 1	1/4	1/8 - 3/16	100	2000
LA0612	Lead expansion anchor	6-8 x 1 1/2	1/4	1/8 - 3/16	100	2000
LA1010	Lead expansion anchor	10-12-14 x 1	5/16	3/16 - 1/4	100	2000
LA1012	Lead expansion anchor	10-12-14 x 1 1/2	5/16	3/16 - 1/4	100	2000
LA1610	Lead expansion anchor	16-18 x 1	3/8	5/16	100	2000

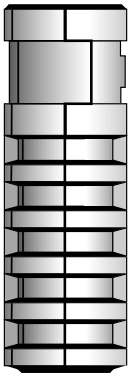

Lag Screw Shields

KEY FEATURES/BENEFITS

- Medium duty anchor used in concrete, tile, brick, cinder block, mortar and stone
- Used with lag screws
- Rustproof

ORDER INFORMATION

Catalog Number	Description	Screw Size x Anchor Length	Drill Diameter	Fractional Screw Size	Quantity	
					Box	Carton
LSS14	Short lag shield	1/4 x 1	1/2	1/4	50	1000
LSS56	Short lag shield	5/16 x 1-1/4	1/2	5/16	50	1000
LSS38	Short lag shield	3/8 x 1-1/4	5/8	3/8	50	500
LSS12	Short lag shield	1/2 x 2	7/8	7/8	25	500
LSS58	Short lag shield	5/8 x 2	3/4	5/8	25	250
LSL14	Long lag shield	1/4 x 1-1/2	1/2	1/4	50	1000
LSL56	Long lag shield	5/16 x 1-3/4	1/2	5/16	50	1000
LSL38	Long lag shield	3/8 x 2-1/2	5/8	3/8	50	500
LSL12	Long lag shield	1/2 x 3	3/4	7/8	25	500
LSL58	Long lag shield	5/8 x 3-1/2	7/8	5/8	25	200

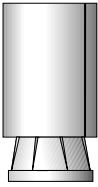

Machine Screw Anchors

KEY FEATURES/BENEFITS

- For medium duty use in concrete, brick or stone
- Closed bottom
- Setting tool provided in each box of anchors
- Fits into irregular holes
- Rust proof

ORDER INFORMATION

Catalog Number	Description	Anchor Diameter & Length	Drill Diameter	Screw Size	Quantity	
					Box	Carton
MS14	Machine screw anchor	1/4-20 x 7/8	1/2	1/4	100	2000
MS56	Machine screw anchor	5/16-18 x 1	5/8	5/16	50	1000
MS38	Machine screw anchor	3/8-16 x 1-1/4	3/4	3/8	50	500

INSTALLATION INSTRUCTIONS

1. Drill the hole equal to the nominal diameter of the anchor. To assure full holding power, do not ream the hole or allow the drill to wobble.*
2. Drill the hole deeper than the intended embedment, but not closer than two diameters to the bottom (opposite) surface of the concrete.
3. Clean the hole with a nylon brush and compressed air.
4. Insert anchor into the hole.
5. Using setting tool, drive expander shield over cone.
6. Position fixture, insert fastener and tighten.

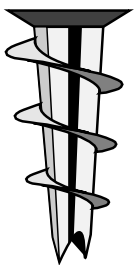

Drywall Augers

KEY FEATURES/BENEFITS

- Available in Zinc or Nylon
- Unique expandable design provides ultimate holding power
- Ideal for fastening to drywall and other low density substrates
- Replaces many types of anchors including molly-type, plastic plugs and toggle type
- Easily removable by simply backing out screw
- No special tools needed. Only a Phillips screw driver or an electric drill

MAXIMUM TENSILE & SHEAR CAPACITY

TENSILE		SHEAR STRENGTH*	
1/2 Drywall 67 lbf	5/8 Drywall 92 lbf	1/2 Drywall 142 lbf	5/8 Drywall 208 lbf

ORDER INFORMATION

Catalog Number	Substrate Thickness	Description	Quantity	
			Box	Carton
DWAN8	3/8 to 1	#8 Nylon	100	1000
DWAS8	3/8 to 1	#8 Steel	100	1000

* **Always wear safety glasses.** Follow drill manufacturer's instructions. Use only solid carbide-tipped drill bits meeting ANSI B212.15 diameter standards.

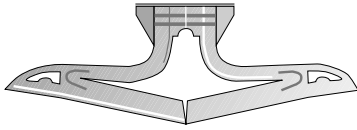

Plastic Toggles

KEY FEATURES/BENEFITS

- For use in hollow drywall, wood, concrete, paneling and masonry tile
- Fast and easy to use
- Inexpensive installation
- Uses screw sizes #6-#16
- If screw is removed, anchor stays in place

ORDER INFORMATION

Catalog Number	Description	Size	Drill Diameter	Wall Depth	Base Screw Size	Quantity	
						Box	Carton
PTS38	Plastic toggle	3/8 short	5/16	3/8	#8 x 1 1/4	100	1000
PTL12	Plastic toggle	1/2 long	5/16	1/2	#10 x 1 1/2	100	800
PTXL58	Plastic toggle	5/8 extra long	5/16	5/8	#10 X 1 3/4	100	800

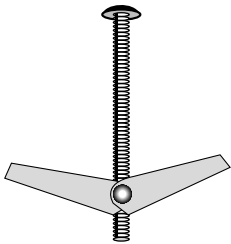

Toggle Bolts

KEY FEATURES/BENEFITS

- Spring wing type hollow wall anchor
- Two-part assembly consisting of a machine screw and a spring wing toggle
- For use in block, wallboard and other hollow base material

ORDER INFORMATION

Catalog Number	Diameter & Length	Drill Diameter	Box	Quantity	Carton
Mushroom Head Combo					
TBM1820	1/8 x 2	1/2	50		500
TBM1830	1/8 x 3	1/2	50		500
TBM1840	1/8 x 4	1/2	50		500
TBM3620	3/16 x 2	9/16	50		500
TBM3630	3/16 x 3	9/16	50		500
TBM3640	3/16 x 4	9/16	50		500
TBM3650	3/16 x 5	9/16	50		500
TBM3660	3/16 x	9/16	50		400
TBM1430	1/4 x 3	11/16	50		400
TBM1440	1/4 x 4	11/16	50		400
TBM1450	1/4 x 5	11/16	50		400
TBM1460	1/4 x 6	11/16	50		400
TBM3840	3/8 x 4	1	25		200
TBM3850	3/8 x 5	1	25		200
TBM3860	3/8 x 6	1	25		200
TBM1240	1/2 x 4	1 5/16	10		80
TBM1260	1/2 x 6	1 5/16	10		80

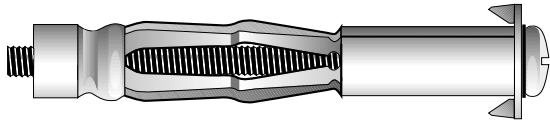

Hollow Wall Anchors

KEY FEATURES/BENEFITS

- Greater holding power than nails or screws in hollow walls
- Use in wallboard, plaster and paneling
- Securely fastens mirrors, pictures, drapery rods, towel bars, etc.
- Fixtures can be removed or replaced without removing anchor

ORDER INFORMATION

Catalog Number	Description	Screw Diameter	Drill Diameter	Wall Thickness	Quantity	
					Box	Carton
HWXS18	Hollow wall anchor – extra short	1/8	5/16	0 - 1/4	100	2000
HWS18	Hollow wall anchor – short	1/8	5/16	1/8 - 1/2	100	2000
HWS36	Hollow wall anchor – short	3/16	3/8	1/8 - 5/8	50	1000
HWS14	Hollow wall anchor – short	1/4	7/16	1/8 - 5/8	50	500
HWL18	Hollow wall anchor – long	1/8	5/16	5/8 - 7/8	100	1000
HWL36	Hollow wall anchor – long	3/16	3/8	5/8 - 1 1/4	50	500
HWL14	Hollow wall anchor – long	1/4	7/16	5/8 - 1 1/4	50	500
HWXL36	Hollow wall anchor – extra long	3/16	3/8	1 1/4 - 1 3/4	25	250

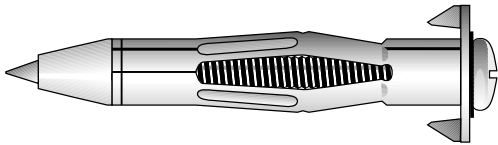

Hollow Wall Drive Anchors

KEY FEATURES/BENEFITS

- Easy and quick installation
- Greater holding power than nails or screws in hollow walls
- Use in wallboard, plaster and paneling
- No predrilling required
- Drives into wall in seconds
- Securely fastens mirrors, pictures, drapery rods, towel bars, etc.

ORDER INFORMATION

Catalog Number	Description	Screw Diameter	Drill Diameter	Wall Thickness	Quantity	
					Box	Carton
HWLD18	Hollow wall anchor - long drive	1/8	5/16	1/8 - 3/4	100	1000
HWSD18	Hollow wall anchor - short drive	1/8	5/16	1/8 - 1/2	100	1000

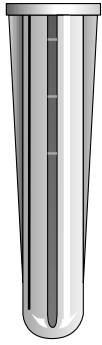

Plastic Conical Anchors

KEY FEATURES/BENEFITS

- For light duty use in concrete, block, brick and wallboard
- Reusable Blister box
- Superior in extreme hot or cold environments
- High quality, low cost installation

ORDER INFORMATION

Catalog Number	Description	Size	Drill Diameter	Quantity	
				Box	Carton
PC0603	Plastic conical anchor	6-8 x 3/4	3/16	100	500
PC0807	Plastic conical anchor	8-10 x 7/8	3/16	100	500
PC1010	Plastic conical anchor	10-12 x 1	1/4	100	500
PC1413	Plastic conical anchor	14-16 x 1-3/8	5/16	50	250

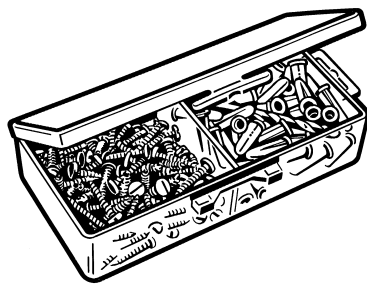

Plastic Conical Anchor Kit

ORDER INFORMATION

Catalog Number	Anchor Diameter & Length	Drill Bit Included	Screws Included	Screw Type	Quantity (PCS)
PC1010 KT	1/4 x 1	1/4 x 4	#10 x 1	Combo Slot/Phil	100

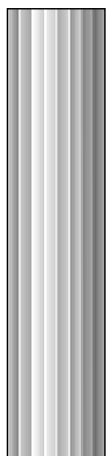

Plastic Plugs

KEY FEATURES/BENEFITS

- Each size anchor accommodates several screw sizes
- Use with sheet metal screws or wood screws
- Ideal for quick installation of lighter objects to concrete, brick, cinder block, etc.
- Superior in hot or cold environments
- Acid resistant

ORDER INFORMATION

Catalog Number	Description	Anchor Diameter & Length	Drill Diameter	Quantity	
				Box	Carton
PPO603	Plastic plug	6-8 x 3/4	3/16	100	2000
PPO810	Plastic plug	8-10-12 x 1	1/4	100	2000

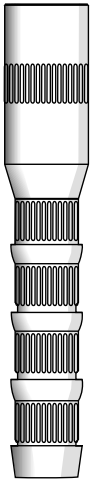

POWER-Sert® High-Performance Anchors

THE ULTIMATE PROBLEM SOLVER



KEY FEATURES/BENEFITS

- **High Holding Values.** Epoxy bond adheres to entire length of anchor body, producing excellent ultimate tensile strength.
- **Instant Holding Power.**¹ Exclusive FRICTION-FIT™ allows immediate installation of fixture to be fastened while epoxy cures.
- **Thru-Hole Installation.**² Ideal for “in-place” fastening applications. No need to move equipment or fixtures to be fastened.
- **Easy to Install.** No special tools required.
- **Shallow Embedment.** Provides excellent holding value while avoiding rebar and “drill-thru.”
- **Close Edge Distance and Spacing.** Epoxy bond and shallow embedment minimize effects of “cone failure.”
- **Vibration Resistant.** Epoxy bond withstands more seismic vibration loading than most standard mechanical anchors.

MAXIMUM TENSILE FOT STATIC LOADS IN CONCRETE

Carbon								
Bolt Size	Drill Diameter	Hole Depth	Inject-Tite Ultimate Tensile Strength	AWF Ulitmate Tensile Strength	Slam-Tite Drill Diameter	Slam-Tite Hole Depth	Slam-Tite Capsule Used	Slam-Tite Ultimate Tensile Strength
1/4	5/16	1 3/4	3380	3543	N/A	N/A	N/A	N/A
5/16	7/16	2 3/4	7497	7879	1/2	3	3/8	4879
3/8	1/2	3 1/4	10633	9215	1/2	3 1/2	3/8	9597
1/2	5/8	4 1/8	15105	13114	5/8	4 1/4	1/2	13142
5/8	7/8	6 1/4	26298	26298	7/8	6 1/4	7/8	27087
3/4	1	7 1/2	46000		1	7	7/8	
1	1 1/2	9 1/2	64000		1 1/2	9	1	
303 Stainless Steel								
Bolt Size	Drill Diameter	Hole Depth	Inject-Tite Ultimate Tensile Strength	AWF Ulitmate Tensile Strength	Slam-Tite Drill Diameter	Slam-Tite Hole Depth	Slam-Tite Capsule Used	Slam-Tite Ultimate Tensile Strength
1/4	5/16	1 3/4	3380	3203	N/A	N/A	N/A	N/A
5/16	7/16	2 3/4	7197	7606	1/2	3	3/8	6570
3/8	1/2	3 1/4	9925	9379	1/2	3 1/2	3/8	9679
1/2	5/8	4 1/8	14805	15650	5/8	4 1/4	1/2	15105
5/8	7/8	6 1/4	25771	26298	7/8	6 1/4	7/8	25771
3/4	1	7 1/2	46000		1	7	7/8	
1	1 1/2	9 1/2	64000		1 1/2	9	1	
1 1/4	1 3/4	12 1/2	86258					
316 Stainless Steel								
Bolt Size	Drill Diameter	Hole Depth	Inject-Tite Ultimate Tensile Strength	AWF Ulitmate Tensile Strength	Slam-Tite Drill Diameter	Slam-Tite Hole Depth	Slam-Tite Capsule Used	Slam-Tite Ultimate Tensile Strength
1/4	5/16	1 3/4	3162	2916	N/A	N/A	N/A	N/A
5/16	7/16	2 3/4	7634	7552	1/2	3	3/8	6570
3/8	1/2	3 1/4	10142	9379	1/2	3 1/2	3/8	9679
1/2	5/8	4 1/8	13387	16687	5/8	4 1/4	1/2	15105
5/8	7/8	6 1/4	26100	28404	7/8	6 1/4	7/8	25771
3/4	1	7 1/2	46000		1	7	7/8	
1	1 1/2	9 1/2	64000		1 1/2	9	1	
1 1/4	1 3/4	12 1/2	86258					

NOTES:

- ¹ FRICTION-FIT™ without full epoxy cure is for light-duty temporary holding only and produces far less than advertised ultimate holding values.
- ² Pre-drilled hole in fixture must be large enough to accommodate correct size of carbide-drill bit.
- Information provided only for the use of a qualified design engineer. Use of technical data by persons not qualified could cause serious damage, injury, or even death.
- Ultimate values are shown. For static loads, use one-fourth of the maximum tensile and shear capacities for the recommended 4:1 safety factor.
- Install POWER-Sert® anchors only with epoxy supplied with anchors or **wej-it**® Fastening Systems branded epoxy products.
- Use cure times recommended by epoxy manufacturer before applying full load to anchor.

MINIMUM CURE TIMES

Minimum Substrate Temp.	Cure Time			Minimum Cure Time		
	AWF Epoxy	Standard Set Epoxy	Fast Set Epoxy	AWF Epoxy	Standard Set Epoxy	Fast Set Epoxy
40°F (5°C)	90 min	F	48 hrs	20 min	F	24 hrs
65°F (18°C)	45 min	48 hrs	36 hrs	8 min	24 hrs	8 hrs
70°F (21°C)	35 min	36 hrs	24 hrs	7 min	12 hrs	2.5 hrs
80°F (27°C)	30 min	24 hrs	12 hrs	6 min	6 hrs	2 hrs
100°F (38°C)	25 min	12 hrs	6 hrs	5 min	4 hrs	1 hr

1. Cure Time is time required before epoxy reaches ultimate strength. Minimum Cure Time is minimum time required before the design or allowable load may be applied.
2. Anchors are to be undisturbed during the minimum cure time.
3. F indicates Fast Set is recommended.

EDGE DISTANCE AND SPACING REQUIREMENTS

Catalog Number	Embedment Depth	Minimum Edge Distance	Minimum Spacing
PS2-14	1 5/8	1 5/8	2 3/8
PS2-56	2 3/8	2 3/8	4 3/4
PS2-38	2 3/4	2 3/4	5 1/2
PS2-12	3 3/4	3 3/4	7 3/8
PS2-58	5 3/4	5 3/4	8 5/8
PS2-34	6 1/2	6 1/2	9 3/4
PS2-1	8 1/2	8 1/2	17
PS2-114	11 1/2	11 1/2	17 1/4

ORDER INFORMATION

Catalog Number		Bolt Size (in)	Dimensions & Length (in)	Quantity	
Carbon Steel	Stainless Steel			Box	Carton
PS2-14	PSS-14	1/4	5/16 x 1 9/16	100	800
PS2-56	PSS-56	5/16	7/16 x 2 3/8	100	800
PS2-38	PSS-38	3/8	1/2 x 2 3/4	50	400
PS2-12	PSS-12	1/2	5/8 x 3 11/16	25	200
PS2-58	PSS-58	5/8	7/8 x 5 3/4	10	80
PS2-34	PSS-34	3/4	1 x 6 1/2	5	40
PS2-1	PSS-1	1	1 1/2 x 8 1/2	5	15
PS2-114	PSS-114	1 1/4	1 3/4 x 11 1/2	5	15

ESTIMATE GUIDE

Bolt Size	Drill Diameter	Minimum Hole	Estimated anchors per cartridge		
			5oz. Cartridge	22oz. Cartridge	28oz. Cartridge
1/4	5/16	1 3/4	250	1100	1400
5/16	7/16	2 3/4	50	230	290
3/8	1/2	3 1/4	40	180	229
1/2	5/8	4 1/8	27	120	150
5/8	7/8	6 1/4	8	38	48
3/4	1	7 1/2	4	20	25
1	1 1/2	9 1/2	-	4	5
1 1/4	1 3/4	12 1/2	-	2	2

INSTALLATION INSTRUCTIONS

1. Select the proper size drill bit from the estimating guide. Drill the hole perpendicular to the work surface.* To assure full holding power, do not ream the hole or allow the drill to wobble.
2. Thoroughly clean hole with compressed air and a wire brush. Dust and debris left in hole will significantly reduce the holding capacity of the anchor.
3. Inject **Inject-TITE® Two-Part Structural Epoxy** into hole to approximately 1/3 to half full.
4. Choose a bolt equal in length to the thread depth plus the material depth. Thread bolt into POWER-Sert® anchor so that offset is equal to the thickness of material to be fastened. Insert POWER-Sert® anchor into hole with slight twisting motion.
5. Drive anchor home with several sharp hammer blows to the head of the nut.
6. Allow epoxy to cure prior to applying maximum load.

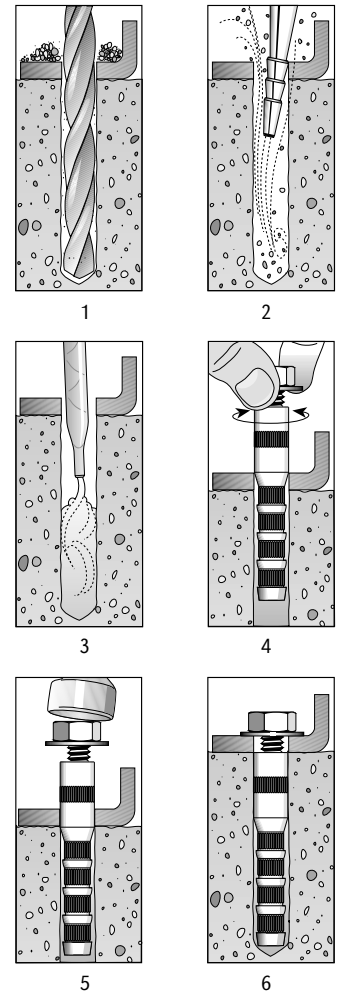

* **Always wear safety glasses.** Follow the drill manufacturer's safety instructions. Use only solid carbide-tipped drill bits meeting ANSI B212.15 diameter standards as listed on back cover.



Inject-TITE® AWF

All-Weather Formula Epoxy Acrylate

KEY FEATURES/BENEFITS

- **Works in all base materials.** Concrete, brick, and stone masonry.
- **Wide variety of applications.**
- **Working Range:** -15°F to 120°F.
- **Sets in water-filled and Damp Holes.**
- **Bonds to diamond core drilled holes.**
- **Styrene Free.**

SPECIFICATIONS, APPROVALS AND LISTINGS

TYPE	
State DOT	Call Customer Service
Approvals	
ASTM	C-881 , Types 1, II, IV and V Grade 3, Class A, B & C

TECHNICAL INFORMATION

TENSION VALUES FOR THREADED ROD

Anchor Diameter (in.)	Drill Diameter (in.)	Embedment (in.)	Critical Edge Distance (in.)	Min. Edge Distance (in.)	Ultimate Tension	
					2,300 psi	4,300 psi
3/8	7/16	1 11/16	4 1/2	1 1/2	3520	5330
3/8	7/16	3 3/8	4 1/2	1 1/2	10685	10785
1/2	9/16	2 1/4	6	2	6435	9780
1/2	9/16	4 1/2	6	2	15405	19985
5/8	3/4	2 13/16	7 1/2	2 1/2	10600	17315
5/8	3/4	5 5/8	7 1/2	2 1/2	29465	32730
3/4	7/8	3 3/8	9	3	15780	24285
3/4	7/8	6 3/4	9	3	28995	43460
7/8	1	3 15/16	10 1/2	3 1/2	17425	31795
7/8	1	7 7/8	10 1/2	3 1/2	40235	56865
1	1 1/8	4 1/2	12	4	22980	35400
1	1 1/8	9	12	4	54715	54945
1 1/4	1 3/8	5 5/8	13 1/2	5	33220	54230
1 1/4	1 3/8	11 1/4	13 1/2	5	74125	80180

SHEAR AND TENSION VALUES FOR REINFORCING BAR

Rebar Size	Drill Diameter	Embedment	Critical Edge Distance	Min. Edge Distance	Ultimate Tension	Ultimate Shear	
					2300 psi	Grade 40	Grade 60
#3	7/16	3 3/8	4 1/2	1 1/2	6220	8800	10560
#4	5/8	4 1/2	6	2	16430	16000	19200
#5	3/4	5 5/8	7 1/2	2 1/2	23310	24800	29760
#6	7/8	6 3/4	9	3	31145	35200	42240
#7	1	7 7/8	10 1/2	3 1/2	36975	48000	57600
#8	1 1/8	9	12	4	43320	62400	74880
#9	1 3/8	11 1/4	13 1/2	5	61340		

ESTIMATING GUIDE

NUMBER OF HOLES PER 28oz. CARTRIDGE

Rod Size (inches)	Hole Size (inches)	Embedment Depth (inches)																		
		2	3	4	5	6	7	8	9	10	11	12	13	14	15	16	17	18	19	20
3/8	7/16	244	163	122	98	81	70	61	55	50	45	41	38	36	33	31	29	28	27	26
1/2	9/16	173	116	87	70	59	50	43	37	36	32	29	27	24	23	22	20	19	19	18
5/8	3/4	89	60	45	36	31	25	23	20	18	17	15	14	13	13	11	11	10	10	9
3/4	7/8	71	47	36	19	24	20	18	17	14	13	13	11	10	10	9	9	9	8	8
7/8	1	60	39	31	24	20	15	15	14	13	11	10	10	9	9	8	8	8	6	6
1	1 1/8	48	33	24	20	17	14	13	11	10	9	9	8	8	6	6	6	6	5	5
1 1/8	1 1/4	43	29	22	18	15	13	11	10	9	9	8	8	6	6	6	5	5	5	5
1 1/4	1 3/8	37	25	19	15	13	11	10	9	8	8	6	6	6	5	5	5	5	4	4
1 1/2	1 5/8	29	20	15	13	10	9	8	6	6	6	5	5	5	4	4	4	4	4	4

Rebar Size (inches)	Hole Size (inches)	Number of Holes per 28oz. Cartridge																		
		2	3	4	5	6	7	8	9	10	11	12	13	14	15	16	17	18	19	20
No. 3	1/2	207	139	104	84	70	60	52	47	42	38	36	33	31	28	27	25	24	23	22
No. 4	5/8	162	108	81	65	55	47	41	37	33	31	28	25	24	22	20	19	19	18	18
No. 5	3/4	131	88	66	52	45	38	33	29	27	24	22	20	19	18	17	15	15	14	14
No. 6	7/8	104	70	52	41	36	31	27	24	22	19	18	17	15	14	14	13	13	11	11
No. 7	1	92	61	46	37	31	27	23	20	19	17	15	14	14	13	11	11	10	10	10
No. 8	1 1/8	79	52	39	32	27	23	20	18	17	15	14	13	11	11	10	10	9	9	9
No. 9	1 3/8	39	27	20	17	14	11	10	9	9	8	8	6	6	5	5	5	5	5	4
No. 10	1 1/2	38	25	19	15	13	11	10	9	8	8	6	6	6	5	5	5	5	5	4

ESTIMATING GUIDE

5 FLUID ONCE CARTRIDGE NUMBER OF ANCHORING INSTALLATIONS PER CARTRIDGE* THREADED ROD

Rod In	Hole Size (inches)	Embedment Depth in Inches			
		2	4	6	8
3/8	7/16	48	24	16	12
1/2	9/16	35	17	12	9
5/8	11/16	25	12	8	6
	3/4	18	9	6	4
3/4	13/16	18	9	6	4
	7/8	14	7	5	4
7/8	15/16	17	8	6	4
	1	12	6	4	3
1	1 1/16	14	7	5	4
	1 1/8	10	5	3	2

* The number of anchoring installations is based upon calculations of hole volumes using ANSI tolerance carbide tipped drill bits, the nominal areas of the reinforcing bars and the stress areas of the threaded rods. These estimates do not account for waste.

MINIMUM CURE TIMES

Minimum Substrate Temp.	Gel Time	Cure Time
-15°F/-26°C	8 hrs.	36 hrs.
-5°F/-21°C	6 hrs.	28 hrs.
0°F/-18°C	4 hrs.	24 hrs.
5°F/-15°C	3 hrs.	22 hrs.
20°F/-7°C	45 min.	6 hrs.
40°F/4°C	20 min.	90 min.
50°F/10°C	15 min.	60 min.
60°F/16°C	8 min.	45 min.
70°F/21°C	7 min.	35 min.
80°F/27°C	6 min.	30 min.
100°F/38°C	5 min.	25 min.
120°F/49°C	4 min.	20 min.

SHELF LIFE

12 months in original unopened container

STORAGE CONDITIONS

Store at 40-80°F

ORDER INFORMATION

ALL WEATHER FORMULA



Catalog Number	Description	Box Quantity
ECA5	AWF Kit - 5 oz. Cartridge, Dispensing Tool and Nozzle	8



Catalog Number	Description	Box Quantity
ECA28	AWF 28oz. Cartridge	8



Catalog Number	Description	Box Quantity
EHT28	Manual Dispensing Tool	1

STATIC MIXING NOZZLES (BREAK-OFF TYPE)



Catalog Number	Description	Box Quantity
ECANZ12	1/2" Nozzle for 5 oz. Cartridge	6/Package
ENZ12	1/2" Nozzle	6/Package
ENZ38	3/8" Nozzle	6/Package

SCREENS FOR HOLLOW WALL APPLICATIONS

Stainless Steel

ESC3815	3/8 x 15	25/Package
ESC1215	1/2 x 15	15/Package
ESC5815	5/8 x 15	10/Package
ESC3415	3/4 x 15	10/Package

Nylon

ESCN3814	3/8 x 14	1
ESCN1214	1/2 x 14	1
ESCN5814	5/8 x 14	1
ESCN3414	3/4 x 14	1

STUD ASSEMBLIES - STRAIGHT CUT

Catalog Number	Dimension (in.)		Quantity Box/Carton
Carbon Steel	Stainless Steel		
Grade 2	304	316	
CS238-S	CSS38-S	CS638-S	3/8 x 5 50/300
CS212-S	CSS12-S	CS612-S	1/2 x 6 1/4 25/150
CS258-S	CSS58-S	CS658-S	5/8 x 7 1/2 10/60
CS234-S	CSS34-S	CS634-S	3/4 x 9 1/2 10/40
CS278-S	CSS78-S	CS678-S	7/8 x 10 1/4 10/40
CS210-S	CSS10-S	•	1 x 11 3/4 5/20
CS2114-S	•	•	1 1/4 x 14 5/20

Stud Assemblies – Nuts and Washers Included.
For Use with Epoxy and Slam-Tites.

* **Always wear safety glasses.** Follow drill manufacturer's instructions. Use only solid carbide-tipped drill bits meeting ANSI B212.15 diameter standards.

INSTALLATION INSTRUCTIONS

Step 1. Drill holes to proper diameter and length.*

Step 2. Clean holes with a nylon brush.

Step 3. Blow concrete dust from hole with oil-free compressed air from bottom up.

Step 4. Static mixer should be placed in back of hole. Fill hole while pulling static mixer out, using constant, uniform pressure, filling hole approximately half full. Rotate the bolt as it is inserted to the back of the hole. Annular space should not exceed 1/8 in. (3.2 mm). Consult tables below for embedment depths and loads.

5 oz. Cartridge Instructions:

1. Remove screw-top lid and end plug.
2. Screw static mixer onto cartridge.
3. Twist-lock dispenser onto cartridge with thumbscrew in full opened position.
4. Extrude adhesive by twisting thumbscrew clockwise until uniform color is achieved. Dispense under constant uniform pressure. If dispensing is altered, re-establish uniform color before continuing.

28 oz. Cartridge Instructions:

1. Remove D plugs from small end of cartridge.
2. Slide retaining nut over static mixer. Secure static mixer to cartridge by screwing retaining nut onto cartridge.
3. Place assembled cartridge into hand gun.
4. Extrude material until uniform color is achieved. Dispense under constant uniform pressure. If dispensing is altered, re-establish uniform color prior to continuing. When using a hand gun, release pressure from gun by pressing thumb button at every pause in dispensing. Re-establish uniform color prior to continuing.



Inject-TITE® Two-Part Structural Epoxy Fast-Set Formula

KEY FEATURES/BENEFITS

- **Non-Shrink.** Won't shrink and cause unwanted forces in member.
- **Non-Sag.** Can be used easily in overhead applications.
- **Low Odor.** Eliminates annoying odors.
- **Solvent Free.** Allows for greater flexibility in applications.
- **Eliminates Expansion Forces.** Can be used close to a free edge.
- **Long Life.** Two-year shelf life and not sensitive to UV light or heat.
- **Wide Range of Applications.** Can be used in a wide variety of applications, including concrete, masonry, and mortar.
- **Water Insensitive Before, During & After Cure.** Can be used in water-filled or moist holes.
- **Resists tensile and shear loads due to earthquake and wind.** Can be used in areas with seismic concerns.
- **Weather Resistant.** Can be used in locations subject to severe exterior weather conditions.

TECHNICAL INFORMATION - INJECT-TITE® TWO-PART STRUCTURAL EPOXY

ULTIMATE LOAD (LBS) FOR THREADED ROD INSTALLED IN STONE AGGREGATE CONCRETE AND STATIC LOADING CONDITIONS

Stud Diameter (in)	Hole Diameter (in)	Embedment (in)	Ultimate Bond Strength Concrete Strength		
			2500 psi	4000 psi	5500 psi
3/8	7/16	3 3/8	7300	8250	9200
3/8	9/16	3 3/8	9560	•	•
3/8	7/16	5 5/8	10980	11360	11740
1/2	9/16	4 1/2	10540	11730	12920
1/2	11/16	4 1/2	14640	•	•
1/2	9/16	7 1/2	14660	17010	19360
5/8	3/4	5 5/8	14800	18870	22940
5/8	7/8	5 5/8	23340	•	•
5/8	3/4	9 3/8	21560	26260	30960
3/4	7/8	6 3/4	22380	25870	29360
3/4	1	6 3/4	29850	34340	38360
3/4	7/8	11 1/4	30320	34340	38360
7/8	1	7 7/8	43280	•	•
1	1 1/8	9	55650	•	•
1 1/4	1 3/8	11 1/4	77860	•	•

AVERAGE ULTIMATE LOAD (LBS) FOR REINFORCING BAR INSTALLED IN NORMAL WEIGHT CONCRETE.

Rebar Size (in)	Drill Diameter (in)	Embedment (in)	Tension Ultimate Bond Strength Concrete Strength		
			2500 psi	4000 psi	5500 psi
13	1/2	3 3/8	7080	9050	11020
14	5/8	4 1/2	12300	14730	17160
15	3/4	5 5/8	16000	18810	21620
16	1	6 3/4	39035	•	•
17	1 1/8	7 7/8	36740	•	•
18	1 1/4	9	42670	•	•

■ For static loads, use one-fourth of the maximum tensile and shear capacities for the recommended 4:1 safety factor.

SPECIFICATIONS, APPROVALS AND LISTINGS

TYPE

State DOT Call Customer Service

Approvals

ICC-ES Legacy Report ER5000

ASTM C-881, Types 1 and IV, Grade 3, Class B&C

Dade County 00-0229.05



ULTIMATE LOADS FOR THREADED ROD INSTALLED IN HOLLOW BLOCK USING INJECT-TITE® FAST-SET FORMULA

Threaded Rod Diameter (inches)	Drill Diameter (inches)	Embedment Depth (inches)	Tension Load (lbs)	Shear Load (lbs)
3/8	1/2	3 1/2	1,500	3,000
1/2	5/8	4	2,500	4,000
5/8	3/4	4 1/2	3,000	5,000
3/4	7/8	6	4,000	6,000

ULTIMATE LOADS FOR THREADED ROD INSTALLED IN GROUT FILLED BLOCK USING INJECT-TITE® FAST-SET FORMULA

Threaded Rod Diameter (inches)	Drill Diameter (inches)	Embedment Depth (inches)	Tension Load (lbs)	Shear Load (lbs)
3/8	7/16	3 1/2	6,900	4,500
1/2	9/16	4 1/2	8,600	6,500
5/8	3/4	5	11,000	9,500
3/4	7/8	6 1/2	15,000	11,500

MINIMUM CURE TIMES

Minimum Substrate Temp.	Fast Set Cure Time	Fast Set Minimum Cure Time
40°F (5°C)	48 hrs	24 hrs
65°F (18°C)	36 hrs	8 hrs
70°F (21°C)	24 hrs	2.5 hrs
80°F (27°C)	12 hrs	2 hrs
100°F (38°C)	6 hrs	1 hrs

- Cure Time is time required before epoxy reaches ultimate strength. Minimum Cure Time is minimum time required before the design or allowable load may be applied.
- Anchors are to be undisturbed during the minimum cure time.
- GEL TIME: (60 g. mass); 35 min. at 73°F ± 2° (23°C) for Standard Set; 8 min. at 73°F ± 2° (23°C) for Fast Set.

ALLOWABLE SPACING & EDGE DISTANCE

	Distance for Full Anchor Capacity (Critical Distance)	Distance for Reduced Anchor Capacity (Minimum Distance)	Reduction Factor
Spacing Between Anchors	24D	8D	.90
Edge Distance - Tension Loads	12D	See Below	See Below
Edge Distance - Shear Loads Thd. Rod	12D	4D	.21
Edge Distance - Shear Loads Rebar	16D	4D	.15

MINIMUM EDGE DISTANCE REQUIREMENTS FOR TENSION LOADS FOR ANCHORS INSTALLED IN CONCRETE

Stud Size (in.)	Minimum Edge Distance	Reduction Factor
3/8	1 1/2	.70
1/2	1 3/4	.66
5/8	1 3/4	.70
3/4	1 3/4	.70
7/8	3 1/2	.70
1	4	.70
1 1/4	5	.70

SHELF LIFE

- Two-year shelf life

STORAGE CONDITIONS

- Store at 40° - 95° F
- Precondition cartridges to over 73° F
- For cold weather (Below 70° F), precondition cartridges slowly to 80-90° F for easier dispensing.

* **Always wear safety glasses.** Follow drill manufacturer's instructions. Use only solid carbide-tipped drill bits meeting ANSI B212.15 diameter standards.

Notes:

- Blended epoxy should be a consistent gray color. Do not use epoxy which is not blended.
- Do not allow mixture to remain in nozzle for more than allowed gel time without movement or setting may occur.
- WARNING:** Avoid contact with skin and eyes. Avoid breathing vapors. May cause allergic reaction. **TREAT EYE CONTACT:** Immediately flush eyes with water for 15 minutes. Obtain medical attention. **TREAT SKIN CONTACT:** Wipe off and immediately wash with soap and water. **TREAT INGESTION:** Do not induce vomiting. Give water or milk to dilute and obtain medical attention. **CLEAN SPILLS:** Insure adequate ventilation. Use absorbent material. **FIGHT FIRE:** Use CO₂, Foam or Dry Chemical. Do not enter a confined area without SCBA. **FOR INDUSTRIAL USE ONLY.**

Health	2
Flammable	1
Reactive	0

ESTIMATING GUIDE - SOLID CONCRETE

Bolt Size (in.)	3/8	1/2	5/8	3/4	7/8
Hole Size (in.)	7/16	9/16	3/4	7/8	1
22 oz. Cartridge, Number of Holes per Cartridge					
3"	128	91	47	37	31
4"	96	68	35	28	24
5"	77	55	28	23	19
6"	64	46	24	19	16
7"	55	39	20	16	12
8"	48	34	18	14	12
9"	43	29	16	13	11

INSTALLATION INSTRUCTIONS

- Select the proper drill bit. Using a solid carbide tipped drill bit that meets the ANSI B212.15 standard and a hammer drill. Proceed to drill the hole perpendicular to the surface and do not allow it to wobble or ream out the hole.*
- Cleanliness of all components is very important to the successful use of any adhesive system.**
Using clean dry oil-free compressed air or a vacuum, remove the bulk of the dust and debris from the bottom of the hole.
Next – Using a brush that is at least as big as the hole in diameter (stiff nylon or wire) or a combination of multiple brushes that are together more than the hole diameter, brush the hole top to bottom and back, being very careful to clean the entire bore all the way to the bottom of the hole.
This must be done at least 3 times. The idea is to clear the concrete of dust allowing a good flow of adhesive into the porosity of the concrete.
Using clean dry oil-free compressed air (air nozzle and plastic tube for extension to the bottom the hole would work well for this) blow out the dust that is brushed off of the walls of the hole. Note – repeated brushings will not significantly affect hole diameter.
Finally – take the brush and repeat the brushing/blowing procedure until not visible dust or debris is blown out of the hole. **(No less than two more times)**
IF you do not follow these cleaning procedures, you could significantly reduce or eliminate the holding capacity of this anchoring system.
- Remove cartridge cap and D-shaped plugs. Place cartridge in dispensing tool and dispense a small amount of adhesive until both black and white components are being ejected. Place a mixing nozzle and retaining nut over the cartridge end and tighten. Now install the cartridge with static mixing nozzle into the injection tool.
- Make sure that adhesive is properly mixed (uniform gray color) when coming out of the end of the static mixing nozzle before filling any hole. This verification should be done on a piece of disposable material and not in the hole. Run a bead and check it to be sure.

Inject-TITE® Anchors in Concrete

- Starting at the BOTTOM of the hole to avoid air pockets inject Inject-Tite® epoxy into the hole until it's 1/3 to 1/2 full.
- Slowly push anchor into the hole, rotating in a clockwise motion. See chart on page 21 for initial bolt-up and cure times.

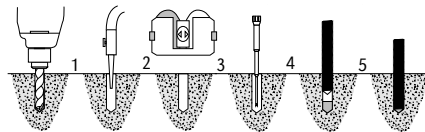

Inject-TITE® Anchors in Masonry

- Inject epoxy starting from the bottom of the screen. Insert screen into the hole. Follow Step 6.

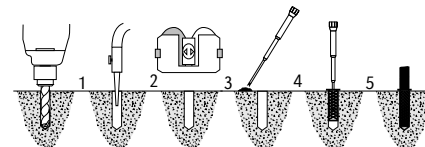

ORDER INFORMATION

INJECT-TITE® ADHESIVE ANCHORS



Catalog Number	Description	Box Quantity
<i>Two component Cartridges</i>		
ECT22F	Fast Set Epoxy	



22 oz. Cartridge 12

Static Mixing Nozzles (break-off style):

ENZ12	1/2" x 18"	6
ENZ38	3/8" x 18"	6



Manual Dispensing Tool:

EHT22	For 22 oz Cartridges	1
-------	----------------------	---



Screens for Hollow Wall Applications

STAINLESS STEEL

ESC3815	3/8" x 15"	3/8"	1/2"	25
ESC1215	1/2" x 15"	1/2"	5/8"	15
ESC5815	5/8" x 15"	5/8"	3/4"	10
ESC3415	3/4" x 15"	3/4"	7/8"	10

NYLON

ESCN3814	3/8" x 14"	3/8"	1/2"	1
ESCN1214	1/2" x 14"	1/2"	5/8"	1
ESCN5814	5/8" x 14"	5/8"	3/4"	1
ESCN3414	3/4" x 14"	3/4"	7/8"	1

STUD ASSEMBLIES - STRAIGHT CUT

Catalog Number	Dimension (in.)		Quantity Box/Carton
Carbon Steel	Stainless Steel		
Grade 2	304	316	
CS238-S	CSS38-S	CS638-S	3/8 x 5 50/300
CS212-S	CSS12-S	CS612-S	1/2 x 6 1/4 25/150
CS258-S	CSS58-S	CS658-S	5/8 x 7 1/2 10/60
CS234-S	CSS34-S	CS634-S	3/4 x 9 1/2 10/40
CS278-S	CSS78-S	CS678-S	7/8 x 10 1/4 10/40
CS210-S	CSS10-S	•	1 x 11 3/4 5/20
CS2114-S	•	•	1 1/4 x 14 5/20

Stud Assemblies – Nuts and Washers Included.
For Use with Epoxy and Slam-Tites.



Inject-TITE® Two-Part Structural Epoxy Standard Set Formula

KEY FEATURES/BENEFITS

- **Non-Shrink.** Won't shrink and cause unwanted forces in member.
- **Non-Sag.** Can be used easily in overhead applications.
- **Low Odor.** Eliminates annoying odors.
- **Solvent Free.** Allows for greater flexibility in applications.
- **Eliminates Expansion Forces.** Can be used close to a free edge.
- **Long Life.** Two year shelf life and not sensitive to UV light or heat.
- **Wide Range of Applications.** Can be used in a wide variety of applications, including concrete, masonry, and mortar.
- **Water Insensitive Before, During & After Cure.** Can be used in water-filled or moist holes.
- **Resists tensile and shear loads due to earthquake and wind.** Can be used in areas with seismic concerns.
- **Weather Resistant.** Can be used in locations subject to severe exterior weather conditions.

TECHNICAL INFORMATION - INJECT-TITE® TWO-PART STRUCTURAL EPOXY

AVERAGE ULTIMATE LOAD (LBS) FOR THREADED ROD INSTALLED IN STONE AGGREGATE CONCRETE AND STATIC LOADING CONDITIONS

Stud Diameter (in)	Hole Diameter (in)	Embedment (in)	Ultimate Bond Strength Concrete Strength		
			2500 psi	4000 psi	5500 psi
3/8	7/16	3 3/8	7300	8250	9200
3/8	9/16	3 3/8	9560	•	•
3/8	7/16	5 5/8	10980	11360	11740
1/2	9/16	4 1/2	10540	11730	12920
1/2	11/16	4 1/2	14640	•	•
1/2	9/16	7 1/2	14660	17010	19360
5/8	3/4	5 5/8	14800	18870	22940
5/8	7/8	5 5/8	23340	•	•
5/8	3/4	9 3/8	21560	26260	30960
3/4	7/8	6 3/4	22380	25870	29360
3/4	1	6 3/4	29850	34340	38360
3/4	7/8	11 1/4	30320	34340	38360
7/8	1	7 7/8	43280	•	•
1	1 1/8	9	55650	•	•
1 1/4	1 3/8	11 1/4	77860	•	•

AVERAGE ULTIMATE LOAD (LBS) FOR REINFORCING BAR INSTALLED IN NORMAL WEIGHT CONCRETE.

Rebar Size (in)	Drill Diameter (in)	Embedment (in)	Tension Ultimate Bond Strength Concrete Strength		
			2500 psi	4000 psi	5500 psi
3	1/2	3 3/8	7080	9050	11020
4	5/8	4 1/2	12300	14730	17160
5	3/4	5 5/8	16000	18810	21620
6	1	6 3/4	39035	•	•
7	1 1/8	7 7/8	36740	•	•
8	1 1/4	9	42670	•	•

- For static loads, use one-fourth of the maximum tensile and shear capacities for the recommended 4:1 safety factor.

SPECIFICATIONS, APPROVALS AND LISTINGS

TYPE

State DOT Call Customer Service

Approvals

ICC-ES Legacy Report	ER5000
ASTM	C-881 , Types 1 and IV, Grade 3, Class B&C
Dade County	00-0229.05



MINIMUM CURE TIMES

Minimum Substrate Temp.	Standard Set Cure Time
65° F (18° C)	48 hrs
70° F (21° C)	36 hrs
80° F (27° C)	24 hrs
100° F (38° C)	12 hrs

- Cure Time is time required before epoxy reaches ultimate strength.
Minimum Cure Time is minimum time required before the design or allowable load may be applied.
- Anchors are to be undisturbed during the minimum cure time.
- GEL TIME: (60 g. mass); 35 min. at 73° F ± 2° (23° C) for Standard Set

ALLOWABLE SPACING & EDGE DISTANCE

Spacing Between Anchors	Distance for Full Anchor Capacity (Critical Distance)	Distance for Reduced Anchor Capacity (Minimum Distance)		Reduction Factor
		Distance for Full Anchor Capacity (Critical Distance)	Reduction Factor	
Spacing Between Anchors	24D	8D	.90	
Edge Distance - Tension Loads	12D	See Below	See Below	
Edge Distance - Shear Loads Thd. Rod	12D	4D	.21	
Edge Distance - Shear Loads Rebar	16D	4D	.15	

MINIMUM EDGE DISTANCE REQUIREMENTS FOR TENSION LOADS FOR ANCHORS INSTALLED IN CONCRETE

Stud Size (in.)	Minimum Edge Distance C	Reduction Factor
3/8	1 1/2	.70
1/2	1 3/4	.66
5/8	1 3/4	.70
3/4	1 3/4	.70
7/8	3 1/2	.70
1	4	.70
1 1/4	5	.70

ORDER INFORMATION

INJECT-TITE® ADHESIVE ANCHORS



Catalog Number	Description	Box Quantity
<i>Two component Cartridges</i>		
ECT22	Standard Set Epoxy	



	22 oz. Cartridge	12
<i>Static Mixing Nozzles (break-off style):</i>		
ENZ12	1/2" x 18"	6
ENZ38	3/8" x 18"	6



Manual Dispensing Tool:

EHT22	For 22 oz Cartridges	1
-------	----------------------	---



Screens for Hollow Wall Applications

STAINLESS STEEL

ESC3815	3/8" x 15"	3/8"	1/2"	25
ESC1215	1/2" x 15"	1/2"	5/8"	15
ESC5815	5/8" x 15"	5/8"	3/4"	10
ESC3415	3/4" x 15"	3/4"	7/8"	10

NYLON

ESCN3814	3/8" x 14"	3/8"	1/2"	1
ESCN1214	1/2" x 14"	1/2"	5/8"	1
ESCN5814	5/8" x 14"	5/8"	3/4"	1
ESCN3414	3/4" x 14"	3/4"	7/8"	1

STUD ASSEMBLIES - STRAIGHT CUT

Catalog Number	Dimension (in.)		Quantity Box/Carton
Carbon Steel	Stainless Steel		
Grade 2	304	316	
CS238-S	CSS38-S	CS638-S	3/8 x 5 50/300
CS212-S	CSS12-S	CS612-S	1/2 x 6 1/4 25/150
CS258-S	CSS58-S	CS658-S	5/8 x 7 1/2 10/60
CS234-S	CSS34-S	CS634-S	3/4 x 9 1/2 10/40
CS278-S	CSS78-S	CS678-S	7/8 x 10 1/4 10/40
CS210-S	CSS10-S	•	1 x 11 3/4 5/20
CS2114-S	•	•	1 1/4 x 14 5/20

Stud Assemblies – Nuts and Washers Included.
For Use with Epoxy and Slam-Tites.

* **Always wear safety glasses.** Follow drill manufacturer's instructions. Use only solid carbide-tipped drill bits meeting ANSI B212.15 diameter standards.

Notes:

- Blended epoxy should be a consistent gray color. Do not use epoxy which is not blended.
- Do not allow mixture to remain in nozzle for more than allowed gel time without movement or setting may occur.
- WARNING:** Avoid contact with skin and eyes. Avoid breathing vapors. May cause allergic reaction. **TREAT EYE CONTACT:** Immediately flush eyes with water for 15 minutes. Obtain medical attention. **TREAT SKIN CONTACT:** Wipe off and immediately wash with soap and water. **TREAT INGESTION:** Do not induce vomiting. Give water or milk to dilute and obtain medical attention. **CLEAN SPILLS:** Insure adequate ventilation. Use absorbent material. **FIGHT FIRE:** Use CO₂, Foam or Dry Chemical. Do not enter a confined area without SCBA. **FOR INDUSTRIAL USE ONLY.**

Health	2
Flammable	1
Reactive	0

ESTIMATING GUIDE - SOLID CONCRETE

Bolt Size (in.)	3/8	1/2	5/8	3/4	7/8
Hole Size (in.)	7/16	9/16	3/4	7/8	1
22 oz. Cartridge, Number of Holes per Cartridge					
3"	128	91	47	37	31
4"	96	68	35	28	24
5"	77	55	28	23	19
6"	64	46	24	19	16
7"	55	69	20	16	12
8"	48	34	18	14	12
9"	43	29	16	13	11

INSTALLATION INSTRUCTIONS

- Select the proper drill bit. Using a solid carbide tipped drill bit that meets the ANSI B212.15 standard and a hammer drill. Proceed to drill the hole perpendicular to the surface and do not allow it to wobble or ream out the hole.*
- Cleanliness of all components is very important to the successful use of any adhesive system.**
Using clean dry oil-free compressed air or a vacuum remove the bulk of the dust and debris from the bottom of the hole.
Next – Using a brush that is at least as big as the hole in diameter (stiff nylon or wire) or a combination of multiple brushes that are together more than the hole diameter, brush the hole top to bottom and back, being very careful to clean the entire bore all the way to the bottom of the hole.
This must be done at least 3 times. The idea is to clear the concrete of dust allowing a good flow of adhesive into the porosity of the concrete.
Using clean dry oil-free compressed air (air nozzle and plastic tube for extension to the bottom of the hole would work well for this) blow out the dust that is brushed off of the walls of the hole. Note – repeated brushings will not significantly affect hole diameter.
Finally – take the brush and repeat the brushing/blowing procedure until not visible dust or debris is blown out of the hole. **(No less than two more times)**
IF you do not follow these cleaning procedures, you could significantly reduce or eliminate the holding capacity of this anchoring system.
- Remove cartridge cap and D-shaped plugs. Place cartridge in dispensing tool and dispense a small amount of adhesive until both black and white components are being ejected. Place a mixing nozzle and retaining nut over the cartridge end and tighten. Now install the cartridge with static mixing nozzle into the injection tool.
- Make sure that adhesive is properly mixed (uniform gray color) when coming out of the end of the static mixing nozzle before filling any hole. This verification should be done on a piece of disposable material and not in the hole. Run a bead and check it to be sure.

Inject-TITE® Anchors in Concrete

- Starting at the **BOTTOM** of the hole to avoid air pockets inject Inject-Tite® epoxy into the hole until it's 1/3 to 1/2 full.
- Slowly push anchor into the hole, rotating in a clockwise motion. See chart on page 21 for initial bolt-up and cure times.

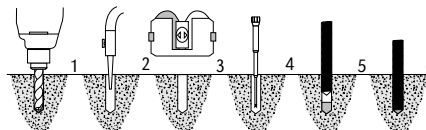

Inject-TITE® Anchors in Masonry

- Inject epoxy starting from the bottom of the screen. Insert screen into the hole. Follow Step 6.

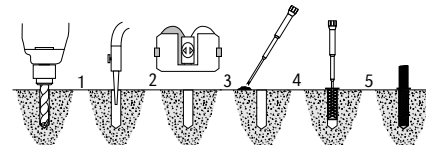



Slam-TITE® Hammer-In Chemical Capsules

KEY FEATURES/BENEFITS

- **Easy to Install.** No setting tool necessary, just use a hammer to drive in.
- **Economical.** Minimal waste, use only the amount you require.
- **Reliable.** Works in all types of weather.
- **Mistake Proof.** 3/8" through 5/8" Capsules can be set either end up. Set larger capsules rounded end down.
- **Eliminates Expansion Forces.** Can be used close to a free edge.
- **Clean.** No disposal of excess material necessary.
- **Less Breakage.** Innovative package design.

APPROVALS

TYPE	
State DOT	Contact Customer Service
Approvals	

TECHNICAL INFORMATION

MAXIMUM TENSILE CAPACITIES

THREADED ROD:

Catalog Number	Threaded Rod Diameter (in)	Drill Diameter (in)	Embedment (in)	Tensile Value in 4000 psi Concrete (lbs)
HMC10-38	3/8	7/16	3 1/2	5395
HMC12-12	1/2	9/16	4 1/4	8318
HMC16-58	5/8	3/4	5 1/2	15287
HMC20-34	3/4	7/8	5 3/4	17985
HMC22-78	7/8	1	7	22481
HMC24-1	1	1 1/8	8 1/4	32372
HMC30-114	1 1/4	1 3/8	11	•

REINFORCED BAR:

Catalog Number	Rebar Size	Drill Diameter (in)	Embedment (in)	Tensile Value in 4000 psi Concrete (lbs)
HMC10-38	#3	1/2	3 1/2	6295
HMC12-12	#4	5/8	4 1/4	9217
HMC16-58	#5	3/4	5 1/2	15287
HMC20-34	#6	1	5 3/4	17985
HMC22-78	#7	1 1/8	7	22481
HMC24-1	#8	1 1/4	8 1/4	32372

NOTES:

- Caution: For ultimate anchorage capacity, use lowest value of anchor capacity, concrete capacity or steel strength.
- Information provided only for use of a qualified design engineer. Use of technical data by persons not qualified could cause serious damage, injury, or even death.
- Ultimate values shown. For static loads, use one-third of the maximum tensile and shear capacities for the recommended 3:1 safety factor.
- Tensile strength data verified by FMPA at the University of Stuttgart. Available upon request.

STORAGE RECOMMENDATIONS

For maximum shelf life, Slam-TITE® Hammer-In capsules should be stored in the original packaging, in a temperature controlled environment (23-80 degrees Fahrenheit). For 3/4, 7/8, 1, 1-1/4 must be standing up with white end down. Shelf life of up to 2 years is possible, for 3/8, 1/2 and 5/8 dia.; 1 year on 3/4 and larger, but higher than recommended storage temperatures and exposure to UV rays may adversely affect the polyester resin and significantly reduce shelf life. As long as the resin has a honey-like flow (not jelled), the capsule should perform appropriately. Some crystallization is normal on 3/4 - 1-1/4.

MINIMUM CURE TIMES

Temperature (degrees Fahrenheit)	Minimum Cure Time
68 and over	10 minutes
50 to 68	20 minutes
32 to 50	1 hour
23 to 32	5 hours

EDGE DISTANCE AND SPACING REQUIREMENTS

Embedment (E) in Anchor Diameters	Spacing	Edge Distance
E ≤ 6d (shallow)	3.5E	1.75E
6d ≤ E ≤ 8d (standard)	2.00E	1.00E
8d ≤ E (deep)	1.50E	0.75E

Health	2
Flammable	1
Reactive	0

ORDER INFORMATION

Catalog Number	Nominal Diameter (in)	Capsule Dimensions	Stud Size (in)	Drill Diameter (in)	Rebar Dimensions	Drill Diameter (in)	Capsule Volume (cubic in)	Embedment Depth (in)	Quantity Capsules/Box
HMC10-38	3/8	3/8 x 3 3/8	3/8	7/16	#3	1/2	0.3	3 1/2	10
HMC12-12	1/2	1/2 x 3 3/4	1/2	9/16	#4	5/8	0.6	4 1/4	10
HMC16-58	5/8	5/8 x 3 3/4	5/8	3/4	#5	3/4	1.1	5 1/2	10
HMC20-34	3/4	3/4 x 4 3/4	3/4	7/8	#6	1	2.0	5 3/4	10
HMC22-78	7/8	7/8 x 7	7/8	1	#7	1 1/8	2.9	7	6
HMC24-1	1	1 x 8 1/4	1	1 1/8	#8	1 1/4	4.2	8 1/4	6
HMC30-114	1 1/4	1 1/4 x 11	1 1/4	1 3/8	•	•	11.6	11	2

STUD ASSEMBLIES - STRAIGHT CUT

Catalog Number	Dimension (in.)		Quantity Box/Carton
Carbon Steel	Stainless Steel		
Grade 2	304	316	
CS238-S	CSS38-S	CS638-S	3/8 x 5 50/300
CS212-S	CSS12-S	CS612-S	1/2 x 6 1/4 25/150
CS258-S	CSS58-S	CS658-S	5/8 x 7 1/2 10/60
CS234-S	CSS34-S	CS634-S	3/4 x 9 1/2 10/40
CS278-S	CSS78-S	CS678-S	7/8 x 10 1/4 10/40
CS210-S	CSS10-S	•	1 x 11 3/4 5/20
CS2114-S	•	•	1 1/4 x 14 5/20

Stud Assemblies – Nuts and Washers Included.
For Use with Epoxy and Slam-Tites.

INSTALLATION INSTRUCTIONS

- All surfaces should be clean and free of grease, oil, and moisture. Base materials must be at least 23° Fahrenheit.
- Select the proper size drill bit. Drill the hole perpendicular to the work surface: To assure full holding power, do not ream the hole, or allow the hammer drill to wobble.*
- Hole depth equals embedment depth, see chart or package for proper embedment for each specific anchor, but not closer than two anchor diameters to the bottom (opposite) surface of the concrete.
- Clean the hole using dry compressed air and a clean wire brush. Dust and debris left in hole will significantly reduce the holding capacity of the anchor.
- Insert straight cut stud into hole. Mark stud to indicate hole depth. Remove stud and check for dust accumulation. If dust is found, go back to step 3.
- Check the capsule (resin must flow like honey). The 3/8", 1/2", 5/8" and 3/4" capsules may be set either end down. Set larger capsules rounded end down.
- Tap stud with hammer until capsule breaks, and then drive stud in with hammer until stud is embedded to mark, indicating desired embedment depth.
- Avoid disturbing stud. Allow resin to cure for the specified time before loading stud.

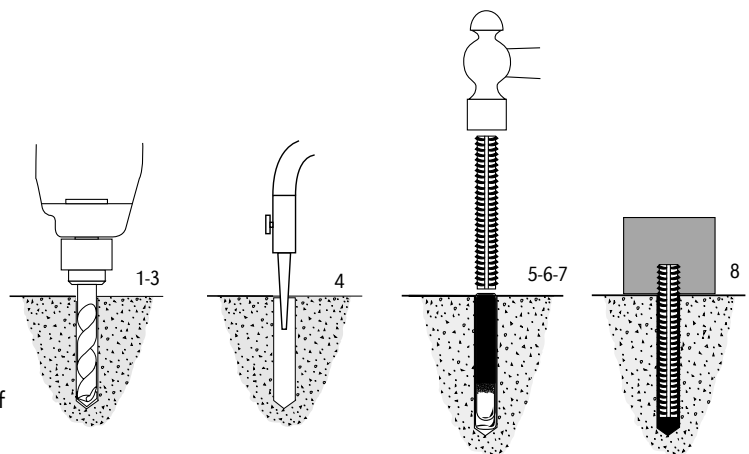

* **Always wear safety glasses.** Follow the drill manufacturer's safety instructions. Use only solid carbide-tipped drill bits meeting ANSI B212.15 diameter standards as listed on back cover.

† Fumes and contact with skin may be harmful.

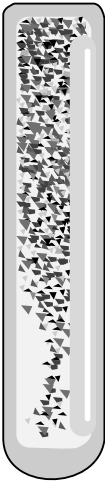

Chemical Capsule Anchors Spin-In

KEY FEATURES/BENEFITS

- **No Expansion Stress.** “Synthetic mortar” bonds stud assembly to concrete. Also performs in lightweight and soft masonry substrates.
- **Useful in Dynamic Load Environment.** Chemical bonding is less likely to “work loose” under shock conditions and vibratory loads.
- **Less Breakage.** Innovative package design.
- **No Waste.**

APPROVALS

TYPE

State DOT

Contact Customer Service

Approvals

TECHNICAL INFORMATION

MAXIMUM TENSILE CAPACITY

Catalog Number	Embedment Depth (in.)	Drill Diameter (in.)	Tension Values 4000 psi (lbs)
M10-18	3 1/2	7/16	4721
M12-12	4 1/4	9/16	6744
M16-58	5	3/4	10116
M20-34	6 5/8	7/8	18210
M22-78	7	1	22481
M24-1	8 1/4	1 1/8	24954
M30-114	11	1 3/8	40466

NOTES:

- Information provided only for use of a qualified design engineer. Use of technical data by persons not qualified could cause serious damage, injury, or even death.
- CAUTION: For ultimate anchorage capacity, use lowest value of bond strength, steel strength or concrete capacity.
- Ultimate values shown. For static bonds, use one-third of the maximum tensile and shear capacities for the recommended 3:1 safety factor.

MINIMUM CURE TIMES

Temperature (degrees Fahrenheit)	Minimum Cure Time
68 and over	10 minutes
50 to 68	20 minutes
32 to 50	1 hour
23 to 32	5 hours

EDGE DISTANCE AND SPACING REQUIREMENTS

Embedment (E) in Anchor Diameters (d)	Spacing	Edge Distance
$E < 6d$ (shallow)	2.00E	1.00E
$6d \leq E \leq 8d$ (standard)	1.50E	1.00E
$8d < E$ (deep)	1.00E	0.75E

STORAGE RECOMMENDATIONS

For maximum shelf life, **wej-it**® Chemical Capsules should be stored in the original packaging, in a temperature-controlled environment (23-80 degrees Fahrenheit) that is well-ventilated and dry. Shelf life of up to 2 years is possible, but higher than recommended storage temperatures and exposure to UV rays may adversely affect the acrylic resin and significantly reduce shelf life. As long as the resin has a honey-like flow (not jelled), the capsule should perform appropriately.

Health	2
Flammable	1
Reactive	0

ORDER INFORMATION - CHEMICAL CAPSULES

Catalog Number	Nominal Diameter (in)	Capsule Dimensions (in)	Capsule Volume (cubic in)	Drill Diameter (in)	Embedment Depth (in)	Quantity Capsules/ Box	Appropriate Stud Size (in)
M10-38	3/8	3/8 x 3 3/8	0.3	7/16	3 1/2	10	3/8
M12-12	1/2	1/2 x 3 3/4	0.6	9/16	4 1/4	10	1/2
M16-58	5/8	5/8 x 3 3/4	1.1	3/4	5	10	5/8
M20-34	3/4	3/4 x 4 3/4	2.0	7/8	6 5/8	10	3/4
M22-78	7/8	7/8 x 7	2.9	1	7	6	7/8
M24-1	1	1 x 8 1/4	4.2	1 1/8	8 1/4	6	1
M30-114	1 1/4	1 1/4 x 11	11.6	1 3/8	11	2	1 1/4

STUD ASSEMBLIES - BEVEL CUT

Catalog Number		Dimensions (in.)	Quantity (in.)	
Carbon Steel Grade 2	Stainless Steel			
304	316			
CS238	CSS38	CS638	3/8 x 5	50/300
CS212	CSS12	CS612	1/2 x 6 1/4	25/150
CS258	CSS58	CS658	5/8 x 7 1/2	10/60
CS234	CSS34	CS634	3/4 x 9 1/2	10/40
CS278	CSS78	CS678	7/8 x 10 1/4	10/40
CS210	CSS10	•	1 x 11 3/4	5/20
CS2114	•	•	1 1/4 x 14	5/20

INSTALLATION INSTRUCTIONS

- All surfaces should be clean and free of grease, oil, and moisture. Base materials must be at least 23 ° Fahrenheit.
- Select the proper size drill bit from the chart right. Drill the hole perpendicular to the work surface: To assure full holding power, do not ream the hole, or allow the hammer drill to wobble.*
- Hole depth equals embedment depth, see chart or package for proper embedment for each specific anchor, but not closer than two anchor diameters to the bottom (opposite) surface of the concrete.
- Clean the hole using dry compressed air and a clean wire brush. Dust and debris left in hole will significantly reduce the holding capacity of the anchor.
- Insert 45° chamfered stud into hole. Mark stud to indicate hole depth. Remove stud and check for dust accumulation. If dust is found on stud, go back to step 3.
- Check the capsule (resin must flow like honey). Install capsules rounded end down.
- Connect the stud assembly on a hammer drill. Break capsule with the 45° chamfered end of stud. Using the hammer drill, drive stud to bottom of hole as indicated by mark on stud. Turn off immediately, DO NOT continue to spin stud after it has reached its intended embedment! Release stud and remove the hammer drill.
- Avoid disturbing the stud. Allow resin to cure for specified time before loading stud.

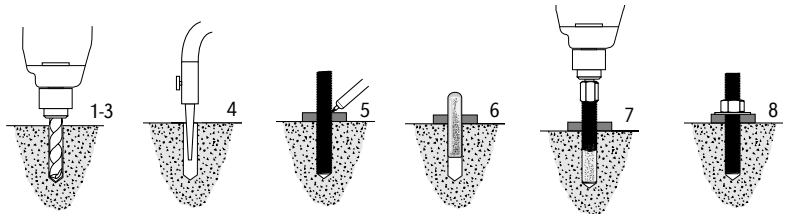

* **Always wear safety glasses.** Follow the drill manufacturer's safety instructions. Use only solid carbide-tipped drill bits meeting ANSI B212.15 diameter standards as listed on back cover.

† Fumes and contact with skin may be harmful.

Ask us about special orders!

- Available in 1/4" to 1 1/4" diameters
- Available in zinc, hot-dip galvanized and stainless steel
- Small minimum quantities

ANSI B212.15 STANDARD

Use solid, carbide-tipped drill bits manufactured to ANSI B212 with standard tolerance on the tip end as follows:

Diameter	Minimum Inches	Maximum Inches
5/32	0.165	0.171
3/16	0.198	0.206
1/4	0.260	0.268
5/16	0.327	0.335
3/8	0.390	0.398
7/16	0.458	0.468
1/2	0.520	0.530
9/16	0.582	0.592
5/8	0.650	0.660
11/16	0.713	0.723
3/4	0.775	0.787
7/8	0.905	0.917
1	1.030	1.042
1 1/8	1.160	1.175
1 1/4	1.285	1.300
1 5/16	1.352	1.367
1 3/8	1.410	1.425
1 1/2	1.535	1.550
1 3/4	1.772	1.792

NOTE: All test data derived from independent testing laboratories as indicated. Testing criteria, methods, and equipment differ between sources and, therefore, definitive performance data and holding values should be obtained by the user through laboratory or job-site testing, utilizing design engineer specified testing criteria, methods, and equipment.

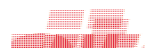

WARRANTY AND REMEDY

All warranties of **wej-it**[®] products and authorized repair thereof, express or implied, including warranties of merchantability and fitness for particular purposes, are specifically excluded except the following: **wej-it**[®] will repair or replace any **wej-it**[®] product which, within six months after sale by **wej-it**[®] or its distributors, is found by **wej-it**[®] to be defective in material or workmanship, normal wear and tear excepted. This is the sole warranty of **wej-it**[®] and the sole remedy available to distributor or buyer. **wej-it**[®] shall not be liable for any injury, loss or damage, direct, indirect, incidental, or consequential, arising out of the use of, or the inability to use, a **wej-it**[®] product.

For the name and location of your nearest authorized  distributor call

800.343.1264

Fax - 800.952.5063

or visit our web site at

www.wejit.com

National Headquarters

2415 E 13 PI
Tulsa, OK 74104-4499
phone 918.744.7444
fax 918.749.3726

Customer Service

Orders/Technical Information

Tulsa, OK
phone 800.343.1264
fax 800.952.5063

Manufacturing Facilities

2415 E 13 PI
Tulsa, OK 74104-4499
10541 E Ute
Tulsa, OK 74116-1522
phone 918.744.7444

Distribution Warehouses

Tulsa, OK
Los Angeles, CA
Salt Lake City, UT
Atlanta, GA
Tampa, FL

wej-it[®] is an associate member of STAFDA.

ANKR-TITE[®], **wej-it**[®], POWER-Sert[®], Inject-TITE[®], Slam-TITE[®], and POWER-Drop[®] are registered trademarks of

wej-it Fastening Systems. Copyright 2004. Patents Pending. Printed in U.S.A.